



WATERTOWN MUNICIPAL UTILITIES

901 • 4TH AVENUE SW • WATERTOWN, SD 57201-4107

PHONE: (605) 882-6233 • FAX: (605) 882-6238

WWW.WATERTOWNMU.COM

Standard Material and Installation Specifications

Revised 2/18/2025.

PART 1.0 – GENERAL REQUIREMENTS	3
1.1 FIRE HYDRANTS	3
1.2 MATERIALS & INSTALLATION	3
1.3 DIRICTIONAL BORING	3
1.4 JOINT RESTRAINTS	3
1.5 TRACER WIRE SYSTEM	4
1.6 THRUST BLOCKING	4
1.7 COPPER WATER SERVICE	4
1.8 PEX WATER SERVICE	4
1.9 SERVICE SADDLE	4
1.10 VALVES	5
1.11 VALVE BOX	5
1.12 VALVE BOX ADAPTOR	5
1.13 CURB STOP & BOX	5
1.14 FITTINGS	5
PART 2.0 – INSTALLATION	5
2.1 HYDROSTATIC TEST	6
2.2 TEMPORARY WATER MAIN & SERVICES	6
2.3 DISINFECTION	6

2.4 EXCAVATION.....	7
2.5 INITIAL PIPE COVERING.....	7
2.6 BEDDING, BACKFILL AND COMPACTION.....	7
2.7 DEWATERING.....	8
2.8 COMPACTION.....	8
PART 3.0 – GENERAL.....	9
3.1 SERVICE INTERRUPTIONS.....	9
3.2 TRAFFIC CONTROL.....	9
3.3 INSTALLATION OF PIPE.....	9
3.4 MECHANICAL JOINTS.....	10
3.5 CONCRETE THRUST BLOCKS.....	10
3.6 TEMPORARY WATER MAIN & SERVICES.....	10
3.7 CONDUCTIVITY.....	11
3.8 DISPOSAL.....	11
3.9 COMMERCIAL/INDUSTRIAL WATER METER VAULT	11

STANDARD DRAWINGS

PART 1.0 – GENERAL REQUIREMENTS

1.1 Fire Hydrants

Shall be provided by the Watertown Municipal Utilities (WMU). The department will not bill the Contractor for supplying the hydrants, but contractor is responsible for installation.

1.2 MATERIALS & INSTALLATION:

1.2.1 WATER MAINS

- A. Pipe furnished by the Contractor or WMU for open cut installation shall be a minimum of new PVC Class 200 SDR 21 200 PSI pressure pipe in standard lengths of 20 feet. C-900 DR 18 and Ductile Iron CL-52 water pipe may also be used as directed by WMU. Gaskets shall be in conformance with ASTM F-477 and must utilize the Rieber joining system.
- B. Fusible PVC manufactured under the trade name Fusible C900 from Underground Solutions Inc. Fusing process shall be as patented by Underground Solutions Inc. and must be trained and certified by Underground Solutions Inc.
- C. All Hydrant leads shall be 6" C-900 DR 18 PVC pipe.

1.2.2 PVC, DUCTILE IRON AND MECHANICAL JOINT FITTINGS:

- A. General: Conform to WMU specifications and the most current edition of AWWA C153, CL-52 for compact Ductile Iron fittings, AWWA C605 for PVC and AWWA C150 for DI pipe.
- B. Mechanical joints are required on all ductile iron fittings.
- C. Fittings shall be cement lined on the interior and 1-mil nominal thickness bituminous coated on the exterior.
- D. Nuts and bolts shall be fluorocarbon coated (Birmingham Fastener Cor-Blue) on all mechanical joints.
- E. Ductile iron shall be wrapped in 8mm polyethylene film.
- F. Approved Manufacturers: Sigma, Star, Tyler or approved equal.
- G. 45* degree fittings must be used for 90* degree turns on mains.

1.3 DIRICTIONAL BORING

- A. All pipe installed utilizing directional boring must be done in accordance to pipe manufacturer specifications. Approved tracing wire for boring is required. See Water Mains 1.2.1 B

1.4 JOINT RESTRAINTS

- A. High-strength ductile iron conforming to the most current edition of ASTM A536.
- B. Fusion bonded epoxy coated or approved equal. Tyler or Smith/Blair currently approved.
- C. Nuts and bolts shall be fluorocarbon coated (Birmingham Fastener Cor-Blue) on all mechanical joints.
- D. Approved Manufacturers: Smith Blair Cam-Lock or approved equal.

1.5 TRACER WIRE SYSTEM

Products shall be in accordance with WMU water specifications, except as

modified herein.

- B. Wire: # 10, solid-strand, soft-drawn copper.
- C. Insulation: 0.045-inches minimum thickness, high molecular weight polyethylene, color blue
- D. Tracer Wire Accepted Manufacturers: Coleman Cable, Kris-Tech Wire or an approved equal.
- E. Splice Kits / Connectors: Shall be able to handle two to four wires per connection and be designed waterproof. Approved manufacturers are Scotchlok DBY by 3M, LV 9000 by SNAPLOC or an approved equal.
- F. Terminal Boxes: Shall be metal and be Concrete/Driveway Snakepit tracing wire access box or approved equal.
- G. Ground rod: 60-inch long, 3/8-inch diameter, copper bonded. Approved manufacturer Eritech with Eritech ground rod clamps or approved equals.

1.6 THRUST BLOCKING

- A. Poured or precast concrete thrust block per WMU standard specifications and details.
- B. Only concrete trust blocks will be acceptable.
- C. Avoid covering joints, bolts, nuts, or fittings with concrete.

1.7 COPPER WATER SERVICE

- A. US Government Type K Soft Copper Tubing
- B. All service lines up to 2 inches shall be type K. copper. Curb stops shall be arch pattern with an operation rod. Service lines greater than 2" shall be constructed from the same standards as the mains. See Section 1.2.1, A & B
- C. Approved Manufacturers: Cerro, Mueller Copper Company, Cambridge-Lee Copper, Halstead, Wolverine or approved equal.

1.8 CROSSLINKED POLYETHYLENE (PEX) WATER SERVICE

- A. Crosslinked Polyethylene (PEX) shall be a minimum pressure class of 200 psi, and shall conform to the most current edition of ANSI/AWWA C904.
- B. Pipe shall have a co-extruded UV Shield made from UV-resistant high density polyethylene, color blue.
- C. PEX pipe shall be provided with 304 stainless steel inserts conforming to NSF61 and AWWA C901. Inserts shall be dimpled and flanged to retain placement within service line.
- D. PEX pipe shall be either 1-inch, 1.5-inch, or 2-inch nominal diameter. No other size is Acceptable. lines greater than 2" shall be constructed from the same standards as the mains. See Section 1.2.1, A & B
- D. PEX service line shall be ran with approved tracing wire from main to building utilizing 8' grounding rods at the foundation and/or water main as required. Stainless Steel Band may be required at main.
- E. Acceptable Manufacturer is Rehau-Municipex

1.9 SERVICE SADDLE

- A. WMU will furnish and install all tapping saddles, corporation stops and complete the wet taps for all water services.
- B. The Contractor shall expose the main at the location of the tap and coordinate with WMU.
- C. Water tapping fees will be charged to the customer when a meter is charged out.

1.10 VALVES

- A. Shall be mechanical joint manufactured by American Flow Control series 2500, Mueller series 2300 or Clow series 2638 and conform to AWWA C515 and able to withstand a working pressure of 250 psi.
- B. Open counterclockwise (left) resilient-seated gate valves.
- C. Standard 2" ductile iron operating nut
- D. All internal and external surfaces shall have fusion bonded epoxy coating in conformance with ANSI/AWWA C550.
- E. Non-rising stem.
- F. 304 stainless steel bonnet and stuffing box hardware.
- G. Wrap all gate valves, joint restraints, and valve boxes in 8 mil polyethylene film.
- H. Valves 16" and larger shall be Butterfly type resilient seated and meet ANSI/AWWA C504 and C516. CLOW class 250B style 4500, MUELLER Lineseal xp,

1.11 VALVE BOX

- A. 2 or 3 piece, cast iron, screw type, adjustable for seven-foot (7') to nine-foot (9') trench. Slip style may be used.
- B. 5-1/4 inch diameter shaft.
- C. Drop cover marked "WATER" with a 1-1/2 inch long skirt.
- D. Include approved valve box adapter.

1.12 VALVE BOX ADAPTOR

- A. Provide manufacturer recommended valve box adaptor.
- B. Must center the valve box over the operating nut.
- C. Allows for keying of the valve nut and eliminates settling or shifting of the valve box.
- D. Approved Products: Valve Box Adaptor II or approved equal.

1.13 CURB STOP & BOX

- A. No lead brass curb stops with copper tube size (CTS) compression connection.
- B. Arch pattern curb box with tracing wire mounting lid, adjustable for the depth of the service.
- C. Operation rod required.
- D. Approved Manufacturers: A.Y. McDonald, Ford Meter Box or Mueller Company.

1.14 FITTINGS

- A. Shall be C153 compact ductile iron mechanical joint type.
- B. Cor-Blue tee bolts shall be used on all mechanical joint fittings.
- C. All mechanical joint fittings shall be restrained with Smith Blair Cam-Lock, TYLER or approved equal joint restraints.
- D. Ductile iron shall be wrapped in 8 mil low-density or 4 mil high density polyethylene film.
- E. Fittings shall be cement lined on the interior and 1-mil nominal thickness bituminous coated on the exterior.

PART 2.0 - INSTALLATION:

- A. All water lines shall be laid with a minimum of seven (7) feet of cover and a maximum of eight (8) feet of cover from the finished grade over the pipe and shall be laid true to line and grade as indicated.
- B. All Ductile Iron pipe and fittings shall be wrapped with 8 mil low-density or 4 mil High Density Polyethylene film.
- C. All valve and fitting sets shall be restrained with a mechanical restraint and shall be suitably provided with concrete thrust blocks poured or set against the fitting of undisturbed earth to insure against disjoints when the piping is placed under pressure. The concrete shall be placed so that the pipe and joints will be accessible for repair.
- D. All pipe, fittings, etc. shall be cleaned of all dirt and trash, and lowered into the trench by boom, or carefully rolled in with a rope. Pipe shall not be dropped into the trench. Before lowering and preferably while suspended, the pipe shall be inspected to detect cracks or flaws.

2.1 HYDROSTATIC TEST:

- A. The Contractor shall perform all the work required in connection with the test and shall provide all the equipment including but not limited to a pressure gauge, water container, appropriate pump, and corporation stop connection. Compressed air will not be allowed to pressurize the main.
- B. The test section shall be placed under a constant 120 psi pressure measured or 1 1/5 times system pressure at the point of lowest elevation for a minimum period of two (2) hours. All valves shall be in fully "open" position during the test period. The test shall be witnessed by WMU.
- C. No pipe installation will be accepted until the pressure change is less than 2 psi during the two (2) hour test duration. No visible leaks will be allowed.
- D. If the test on same section fails twice, the next tests will be billed to contractor at current WMU rates.

2.2 TEMPORARY WATER MAIN & SERVICES

- A. Temporary water main, services and appurtenances that may come into contact with water shall meet the requirements of NSF/ANSI Standard 61: Drinking Water System Components - Health Effects and NSF/ANSI 61 Annex G, NSG/ANSI 372.
- B. PVC piping shall be in conformance with the most current edition of AWWAC900 and C905 Standards. CertainTeed-Certa-Lok Yelomine or approved equal.

2.3 DISINFECTION:

- A. Before being placed in service, the entire line shall be chlorinated. Chlorine may be applied by using calcium hypochlorite and water mixture. The chlorinating agent shall be applied evenly throughout the section of main at a dosage of not less than 25 mg/L. A measurable free chlorine residual of not less than 10 mg/l with a contact time of 24 hours in accordance with A.W.W.A. C651-14. Mains shall be filled and flushed by the Department. A residual of not less than 25 mg/L shall be produced in all parts of the lines during the chlorination process, all valves, and accessories on the new main shall be operated. Extreme care shall be taken to prevent any highly chlorinated water from entering Departments existing water system. After chlorination, the water shall be flushed from the line at its extremities until the replacement water tests indicate a normal Department chlorine residual.

High chlorinated water shall be de-chlorinated and discharged in a manner that will not harm any waterway, lake, or stream which may affect fish or aquatic life. The department shall arrange for any permits required for the discharge of chlorinated water.

- B. After disinfection, 2 consecutive bacteriological water samples shall be collected by the Department and sent to the State Health Department for analysis. The system shall be disinfected by the Owner until negative results are obtained in the analysis.

2.4 EXCAVATION:

- A. All excavation of whatever substances encountered shall be performed by the Contractor to the depths indicated on any plans.
- B. Except as otherwise shown all excavation shall be made to open cut. The banks of trenches shall be vertical to a point level with the top of the pipe. The width of the trench shall be six (6) inches minimum and twelve (12) inches maximum on each side of the pipe bell. Trench bottom shall provide uniform bearing and support for each section of pipe. Trench stabilization material shall consist of 3/4 to 4-inch crushed angular, well-graded material. Use of trench stabilization material will not eliminate the need for water main bedding material.
- C. All pipes shall be installed with approved bedding material to insure uniform support of pipe. Bedding material shall be a minimum of three (3) inches below the pipe and approximately six (6) inches past the outside edge of pipe. If the trench is inadvertently excavated deeper than necessary, it shall be backfilled to the proper grade with approved compacted gravel to provide uniform bedding and shall be at the Contractors expense.
- D. Granular material shall be minus 1 inch with not more than 10 percent passing the No. 20 sieve. Under no conditions will deleterious materials be allowed as bedding material when over-excavation occurs. Where groundwater is encountered, or moisture content is negatively impacting compaction, pea rock shall be required for bedding.
- E. The Contractor shall plug the unfinished ends of all water lines to prevent entrance of water, earth, or any foreign materials.
- F. The Contractor shall remove and dispose of all water which collects in the trenches until the water lines and other appurtenances are in place and sealed against the entrances of water. The Contractor shall control surface water in the vicinity of the trench excavation to prevent water from flowing into the trenches. In no case shall water or foreign materials be allowed to enter the waterlines.
- G. All trenches shall be backfilled immediately after pipe is laid therein, unless other protection of pipeline is directed. Under no circumstances shall water be permitted to rise in un-backfilled trenches after the pipe has been placed. No material shall be used for backfilling that contains frozen earth, debris, stones having any dimension greater than six (6) inches, or earth with an exceptionally high moisture content.

2.5 INITIAL PIPE COVERING:

- A. In all cases for backfill over the pipe, only selected materials shall be used. The backfilling shall be placed in uniform layers.

2.6 BEDDING AND BACKFILL

- A. Pipe bedding is required on all water piping in accordance with WMU specifications, standard details, and the details in the plans.
- B. Place specified bedding material completely under pipe haunches in uniform layers.
- C. Hand (shovel) tamp along pipe within haunch zone to provide a solid pipe foundation, completely free of voids.
- D. Place backfill in uniform loose lifts not to exceed 6-inches prior to compaction. Complete compaction and required testing prior to placing next layer.
- E. Topsoil may not be used to backfill any trench. Utilize acceptable onsite material only.

2.7 DEWATERING

- A. Dewatering is the Contractor's responsibility.
- B. Review geotechnical exploration report if available.
- C. Dispose of groundwater is a safe matter approved by the South Dakota Department of Agricultural and Natural Resources (SDDANR).
- D. Water may not, in any case, be directed into any sanitary sewer system.
- E. If dewatering is needed, it must be approved by WMU prior to any wells placed or no payment will be made.
- F. Dewatering shall be constructed to mean the continuous pumping of water with wells which are required to maintain a satisfactory excavation.
- G. Sump or trash pumps used to pump water out of bottom of ditch will not be considered dewatering but are considered incidental and part of the per foot bid for water main installation.
- H. Once dewatering wells are placed, the cost will be set at \$40.00 per linear foot and no extra will be paid.
- I. The footage of dewatering will be determined by the distance between the two end wells. If only one well is needed, then the footage shall be 50 feet on each side of the well, or a total of 100 feet paid.
- J. Dewatering discharge permits shall be obtained by the WMU.

2.8 COMPACTION

- A. Contractor shall be responsible for all compaction, along with the coordination of the compaction tests.
- B. WMU is responsible for the costs of compaction tests. If a compaction test fails more than two times, the Contractor will then be responsible for all subsequent test costs.
- C. All compaction test results must be shared with WMU for approval.
- D. Avoid compaction directly over the pipe that may damage the system.
- E. Compaction of backfill shall be minimum 95% Standard Proctor density and within +/- 3% optimum moisture content.
- F. In the upper 3-feet of the subgrade, compaction shall be minimum 97% Standard Proctor density and within +2% to -2% optimum moisture content.
- G. Drying operations shall be performed as needed to meet the required moisture conditions.

- H. Traveled Ways (roadways, access roads, roadway approaches and parking lots):
For areas where the ditch is within the bounds of a traveled way, the backfill above the initial pipe covering shall be well tamped by mechanical means to a minimum of 95% of maximum dry density as established by standard proctor as per SD104 and AASTHO T99, before successive lifts are placed.
- I. Road Ditches, Right of Ways, and Open Fields: Compaction in road ditches, rights-of-way and open fields shall be compacted between a minimum of 85% and 95% maximum ASTY-D698 density including the top foot which shall be SDDOT base course or approved topsoil.
- J. Surplus material remaining after backfilling is complete, shall become the property of the Contractor, and shall be his duty to dispose of the same at his own expense.

PART 3.0 - GENERAL

3.1 SERVICE INTERRUPTIONS

- A. Service interruptions are not permitted until approved by the Owner.
- B. Notify Owner at least 5 days in advance of any service interruption.
- C. Night or weekend water shutdowns may be required to minimize service disruption.

3.2 TRAFFIC CONTROL

- A. Traffic control shall be the responsibility of the Contractor.
- B. Provide in conformance with the most current edition of the Manual of Uniform Traffic Control Devices (MUTCD).
- C. No separate payment will be provided for traffic control.
- D. All traffic control measures are to be included in your overall bid items and will not be a separate item.

3.3 INSTALLATION OF PIPE

- A. Conform to the latest revision of AWWA C605 and the instructions provided by the manufacturer.
- B. Comply with the most current edition of OSHA Excavation Safety Standards. Whenever necessary to provide safe working conditions in conformance with safety regulations, the Contractor shall provide suitable shoring, sheathing, and bracing to protect all excavations.
- C. In accordance with the law, the Contractor shall request utility locates from South Dakota One Call prior to ground disturbances.
- D. Uncover utilities to verify horizontal and vertical alignment in advance of trenching.
- E. All existing utilities shall be protected from damage during excavation and backfilling, and if damaged, Contractor shall call 811 and wait for the utility representative to respond. If a gas line is hit, Contractor shall call 911 also and maintain a safe distance from the leak until the proper authorities arrive. Any damage to existing utilities shall be repaired or replaced by the Utility owner and at the Contractors expense.
- F. Excavate as necessary to maintain required cover and provide bedding as specified.

- G. The minimum cover depth over any water pipe (mains or services) shall be no less than seven feet (7-ft) from finished subgrade elevation.
- H. Maximum bury depth from finished street surface shall be 8-ft.
- I. Use suitable equipment for handling all pipes, fittings, valves, and hydrants. Any damage caused by handling or laying shall be at the Contractor's own expense.
- J. Approval must be provided by the WMU Representative for any variance in the required cover depth.
- K. No pipe or appurtenances shall be laid in water or when trench conditions are unsuitable for safe work.
- L. Temporarily cap or plug pipe at the end of each day or during interruptions in work to prevent water, debris, and animals from entering the pipe.
- M. Inspect pipe for any cracks, flaws, or defects prior to installation. All dirt or foreign materials shall be removed from the inside of the pipe.
- N. Clean gaskets and spigot and apply gasket lubrication as recommended by the manufacturer. The lubricant shall be approved for used with potable water.
- O. Insert spigot into bell end. Utilize reference marks on pipe to avoid over insertion.
- P. Install tracer wire and appurtenances.
- Q. Monitor weather forecasts and take appropriate measures to minimize flooding potential, protect construction progress, and minimize the transport of sediment leaving the site.
- R. Remove excavated material that is unsuitable for re-use from site.
- S. Maintain vertical separation of 18-inches minimum between the sanitary sewer main and the water main.

3.4 MECHANICAL JOINTS

- A. Install per manufacturer's recommendations /instructions.
- B. Clean and lubricate the socket and plain end of the fitting.
- C. Place joint restraint gland and gasket on the pipe.
- D. Insert the pipe into the socket and press the gasket into the recess.
- E. Install bolts and nuts to connect the joint restraint gland to the mechanical joint.
- F. Maintain the same distance between the gland and face of the flange by tightening the bolts in an alternating fashion. Tighten to supplier specified torque.
- G. Tighten the torque limiting twist off nuts until all wedges are in full contact with the pipe surface. Tighten in an alternating fashion until all torquenuts have been twisted off.

3.5 CONCRETE THRUST BLOCKS

- A. Poured or precast concrete thrust block per WMU standard specifications and details.
- B. Only concrete trust blocks will be acceptable.
- C. Avoid covering joints, bolts, nuts, or fittings with concrete.

3.6 TEMPORARY WATER MAIN & SERVICES

- A. Temporary water main shall be a minimum of 2-inch diameter.
- B. Temporary water mains must be disinfected, flushed, and sampled prior to making any temporary service connections.

- C. Temporary water main shall be observed for any leaks, and any leaks shall be repaired prior to disinfecting and sampling.
- D. The Contractor is responsible for notifying all customers of service disruption. Water service connections shall be made during the day or at other suitable times to minimize disruption to customers.
- E. Piping shall be buried to protect it from damage where the pipe crosses driveways, entrances, pedestrian crossings, opened sidewalks, entrances, etc.
- F. Contractor shall provide a temporary water main layout and operation plan to WMU a minimum of one week prior to beginning installation.
- G. Contractor shall provide a 24-hour, 7 days a week contact person who will be responsible for making necessary repairs to the temporary system and who has adequate parts, equipment, knowledge, and capabilities to make the repairs in a timely manner.
- H. Temporary water mains, services and appurtenances that may come into contact with water shall meet the requirements of NSF/ANSI Standard 61: Drinking Water System Components - Health Effects and NSF/ANSI 61 Annex G, NSG/ANSI 372.
- I. PVC piping shall be in conformance with the most current edition of AWWAC900 and C905 Standards.
- J. Approved Projects: CertainTeed-Certa-Lok Yelomine or approved equal.
- K. All temporary water mains shall use a hydrant meter with back flow device.

3.7 CONDUCTIVITY

- A. Conductivity testing will be required by the Contractor.
- B. Test all lines, including hydrant leads and stubs.
- C. A WMU representative must be onsite and observe the conductivity test to verify locating needs.
- D. If the tracer wire system does not function as intended, the Contractor must repair the system to the satisfaction of WMU.

3.8 DISPOSAL

- A. Disposal of all waste materials shall be in a legal manner offsite. Burial waste materials is not permitted.
- B. The word 'Remove' or 'Removal' in the plans shall include physically removing and offsite disposal of removed materials.
- C. The Contractor may not abandon pipe in-place unless specifically noted in the plans.

3.9 COMMERCIAL/INDUSTRIAL WATER METER VAULT

SEE STANDARD DRAWING:

WATER MAIN VAULT PENETRATION

- A. Garlock manufacture or approved equal.
- B. Pressure resistant to 20psig (40 ft of head)
- C. For standard applications, use EPDM rubber (black)
- D. For oil resistance, use Nitrile rubber (green)
- E. For temperature resistance, use Silicone rubber (gray)
- F. For fragile pipe, use low durometer EPDM rubber (blue) Shore 40 ± 5
- G. Hardware options – S316 Stainless Steel and Zinc Dichromate Coated Steel (1470 hr salt spray tested) hardware.

Garlock



LINK-SEAL® Modular Pipe Sealing System For Wall Penetrations

SPECIFICATIONS:

Pressure resistant to 20psig (40 ft of head)

For standard applications, use EPDM rubber (black)

For oil resistance, use Nitrile rubber (green)

For temperature resistance, use Silicone rubber (gray)

For fragile pipe, use low durometer EPDM rubber (blue) Shore 40 ± 5

Hardware Options - S316 Stainless Steel and Zinc Dichromate Coated Steel (1470 hr salt spray tested) hardware

TYPICAL COMMERCIAL



TYPICAL RESIDENTIAL METER PIT

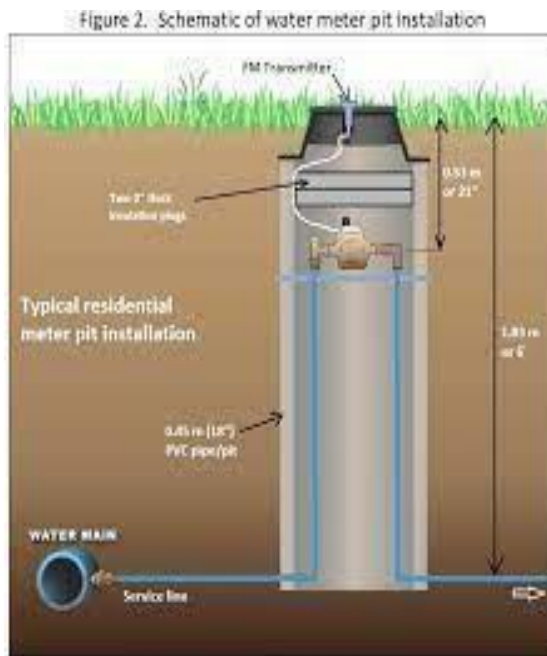

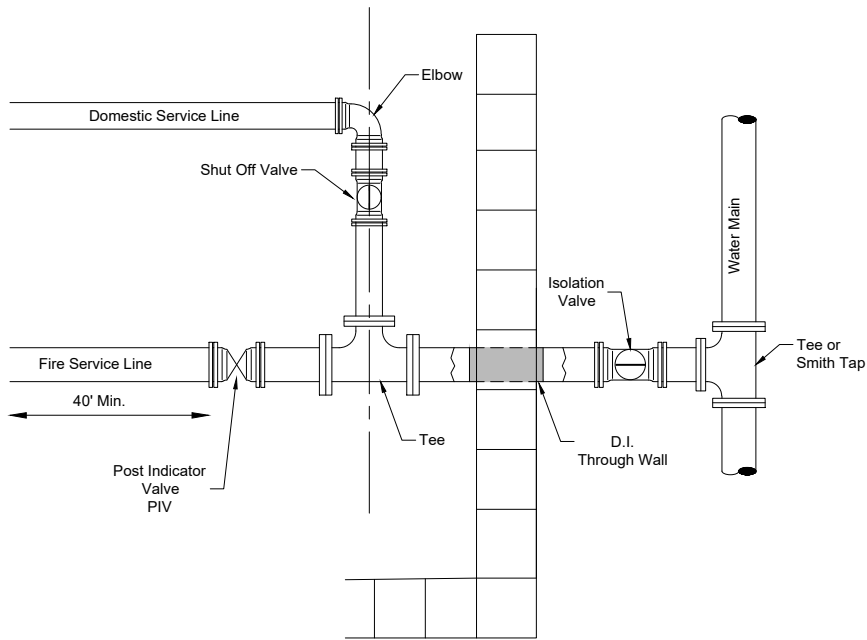

Fire Service Line with PIV
Not to scale

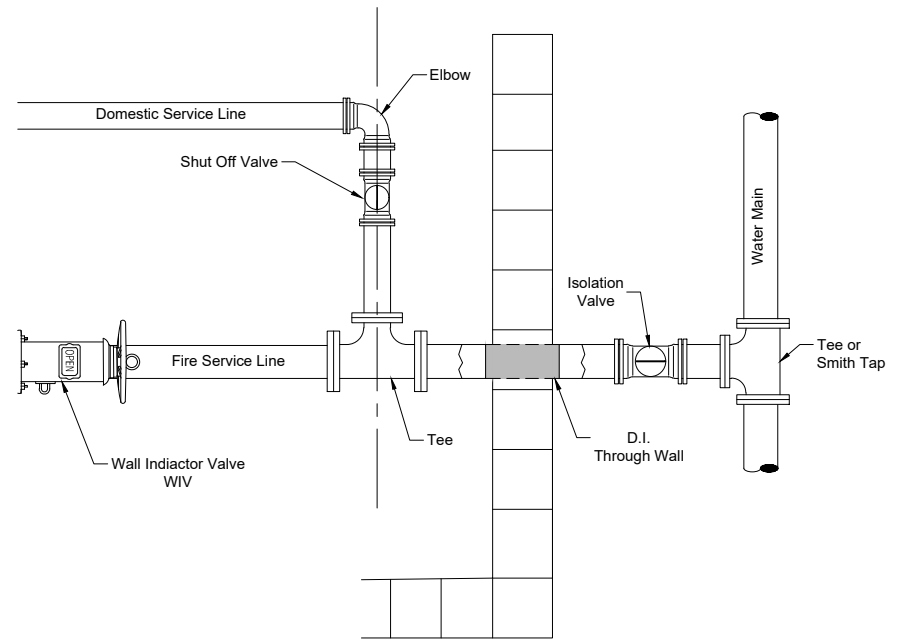

Fire Service Line with WIV
Not to scale

Issued: December, 2022

General Notes:

1. Fire service line and any domestic services branching from the fire service line are privately owned and maintained after the isolation valve.
2. Domestic service lines to have shutoff valves at or near the property line:
4" and larger service to install gate vales.
2" and smaller service to install curb stop.

**Combined Fire & Domestic Service Line Configuration
Inside Structure**

Watertown Municipal Utilities
901 4th Ave. SW
Watertown, S.D. 57201

Specification
Reference

Sheet
Number

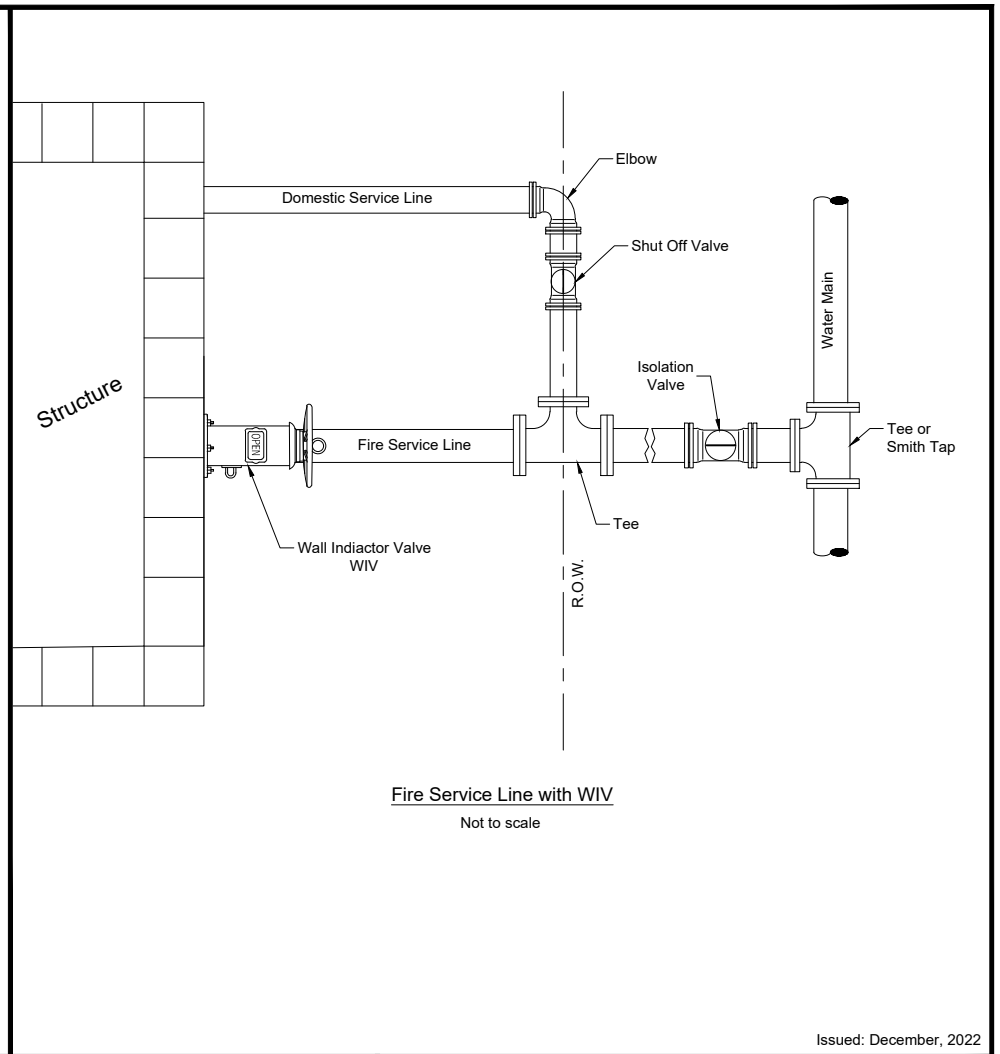
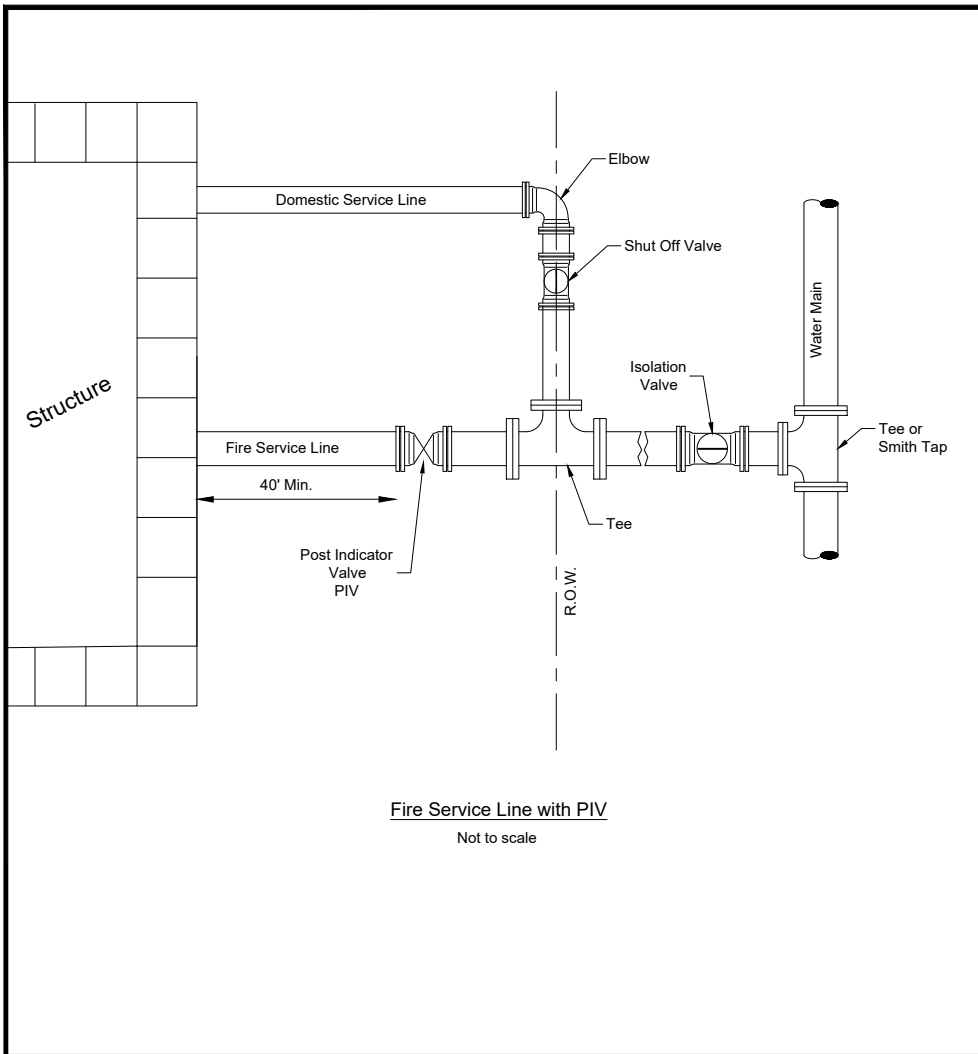

Issued: December, 2022

General Notes:

1. Fire service line and any domestic services branching from the fire service line are privately owned and maintained after the isolation valve.
2. Domestic service lines to have shutoff valves at or near the property line:
 4" and larger service to install gate vales.
 2" and smaller service to install curb stop.

**Combined Fire & Domestic Service Line Configuration
Outside Structure**

Watertown Municipal Utilities
 901 4th Ave. SW
 Watertown, S.D. 57201

Specification
 Reference

Sheet
 Number

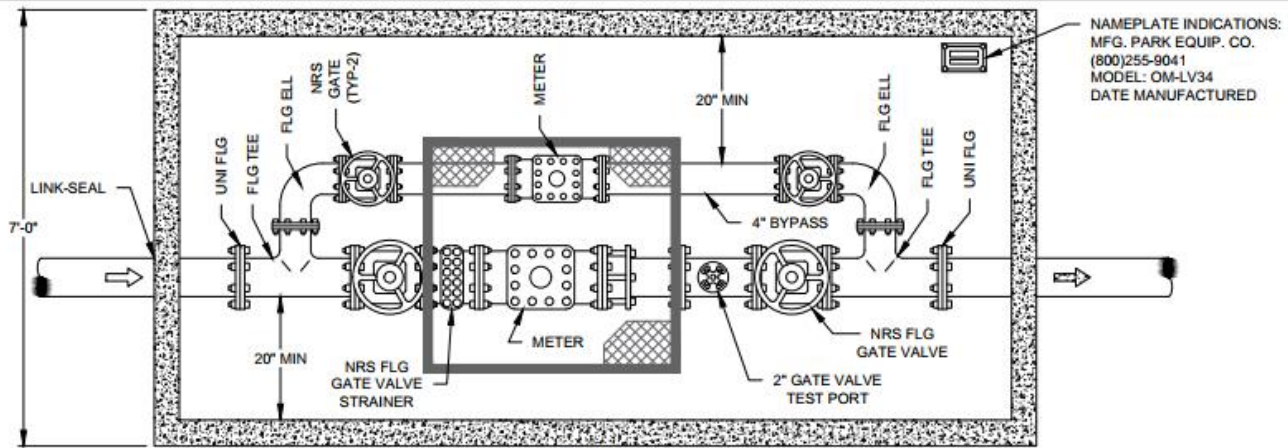

PLAN VIEW

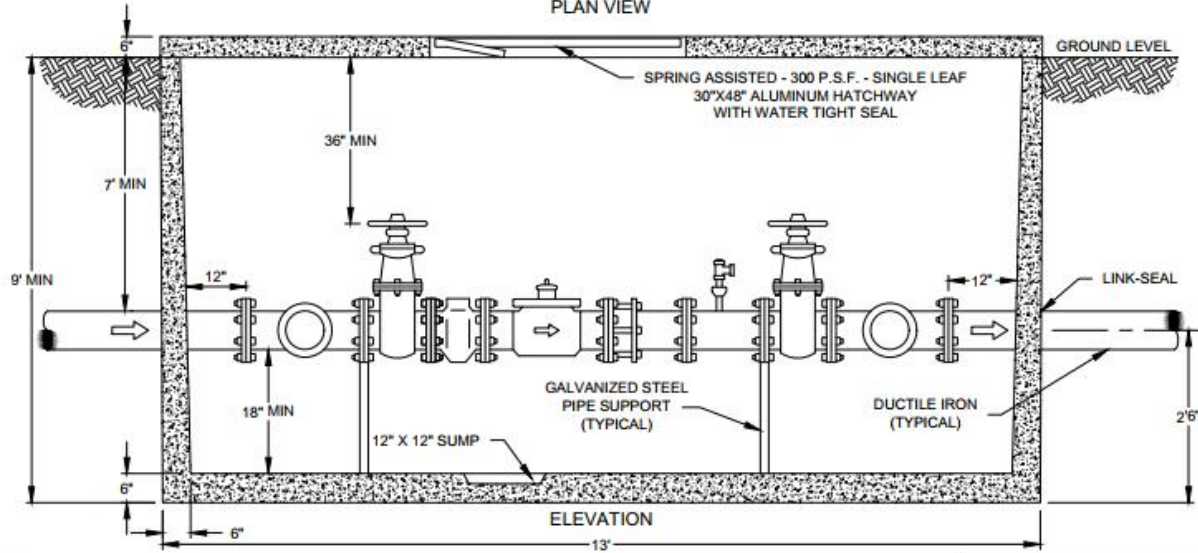

ELEVATION

NAMEPLATE INDICATIONS:
MFG. PARK EQUIP. CO.
(800)255-9041
MODEL: OM-LV34
DATE MANUFACTURED

Issued: December, 2022

General Notes:

1. Fire service line and any domestic services branching from the fire service line are privately owned and maintained after the isolation valve.
2. Domestic service lines to have shutoff valves at or near the property line:
4" and larger service to install gate valves.
2" and smaller service to install curb stop.

**Commercial/Industrial
Meter Pit**

Watertown Municipal Utilities
901 4th Ave. SW
Watertown, S.D. 57201

Specification
Reference

Sheet
Number

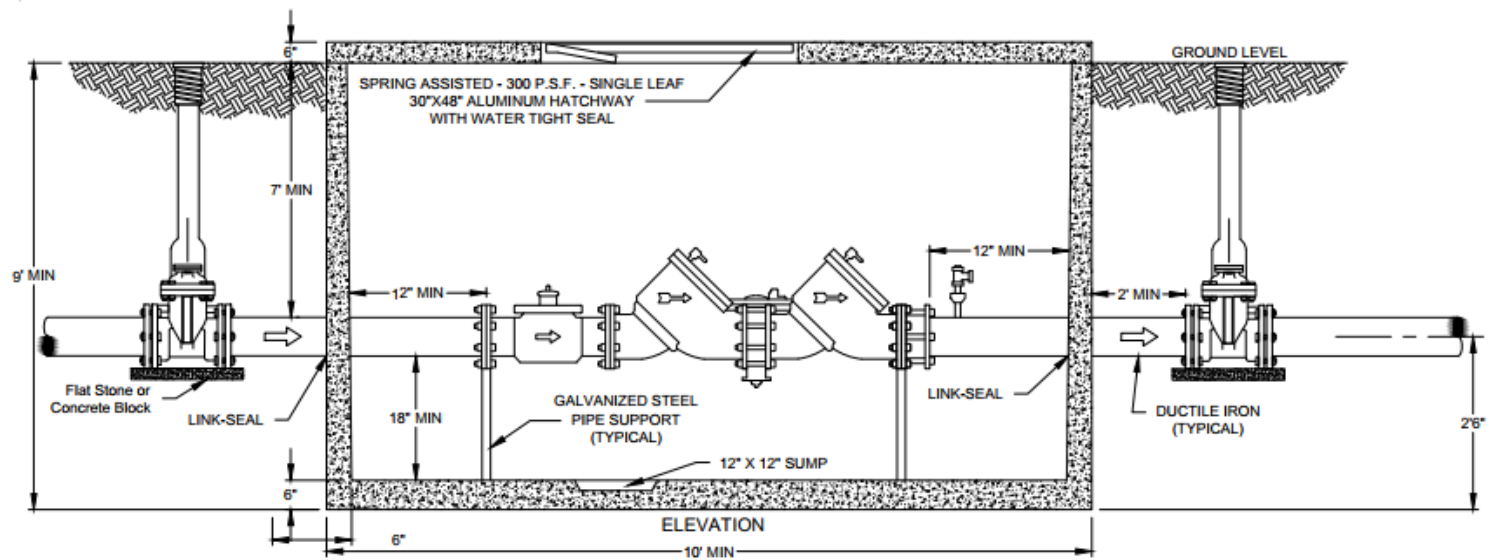
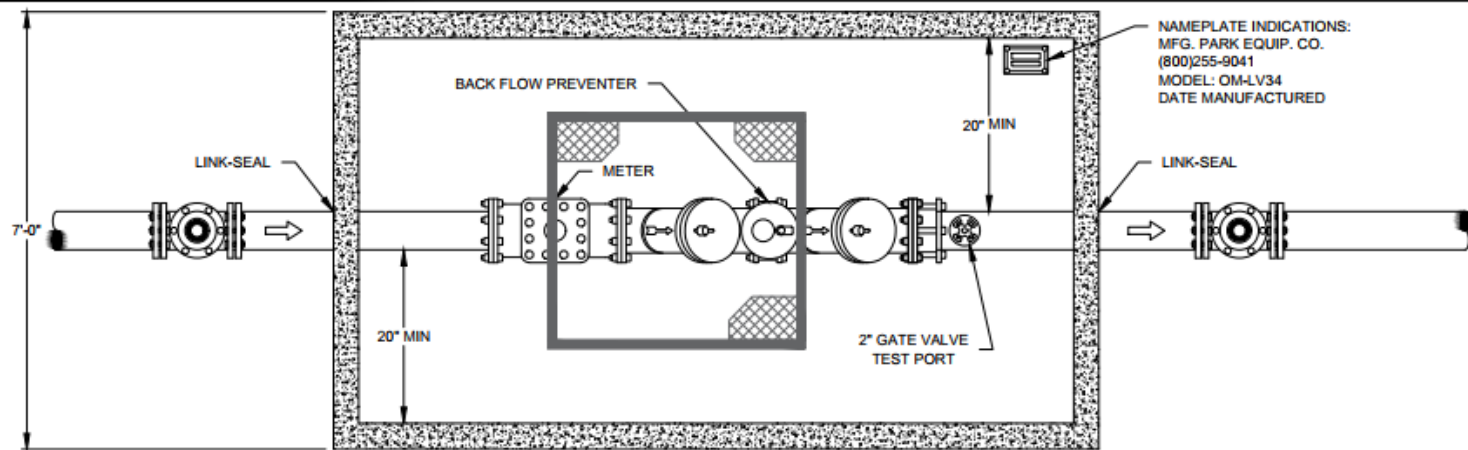

Issued: January, 2024

General Notes:

1. Fire service line and any domestic services branching from the fire service line are privately owned and maintained after the isolation valve.
2. Domestic service lines to have shutoff valves at or near the property line:
4" and larger service to install gate valves.
2" and smaller service to install curb stop.

**Commercial/Industrial
Meter Pit with Backflow Preventer and Valves Outside**

Watertown Municipal Utilities
901 4th Ave. SW
Watertown, S.D. 57201

Specification
Reference

Sheet
Number

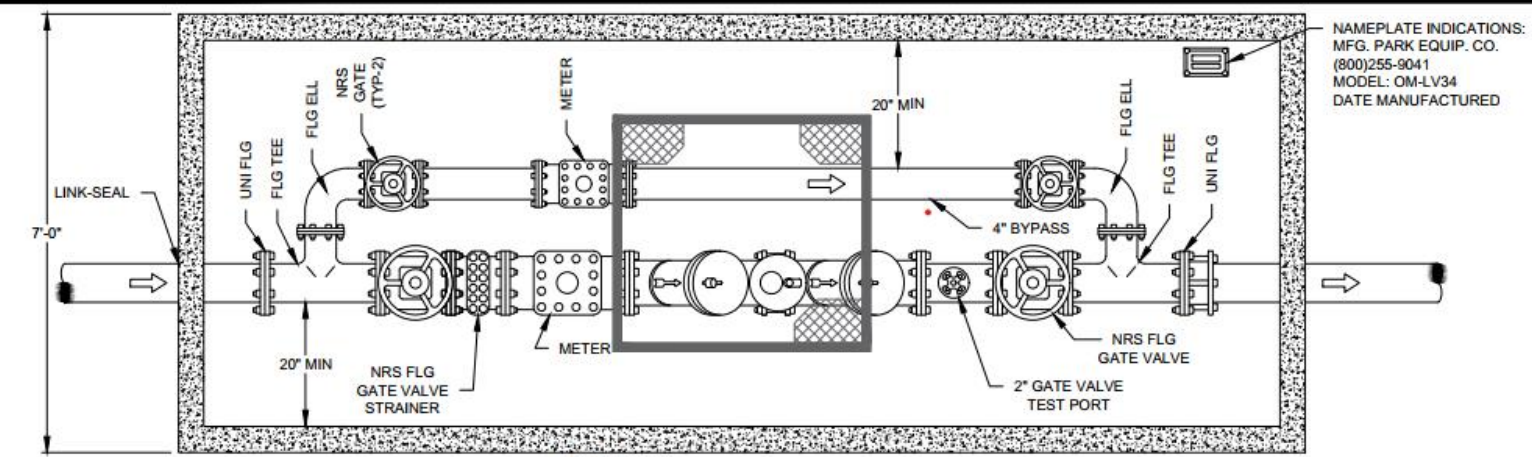

NAMEPLATE INDICATIONS:
MFG. PARK EQUIP. CO.
(800)255-9041
MODEL: OM-LV34
DATE MANUFACTURED

PLAN VIEW

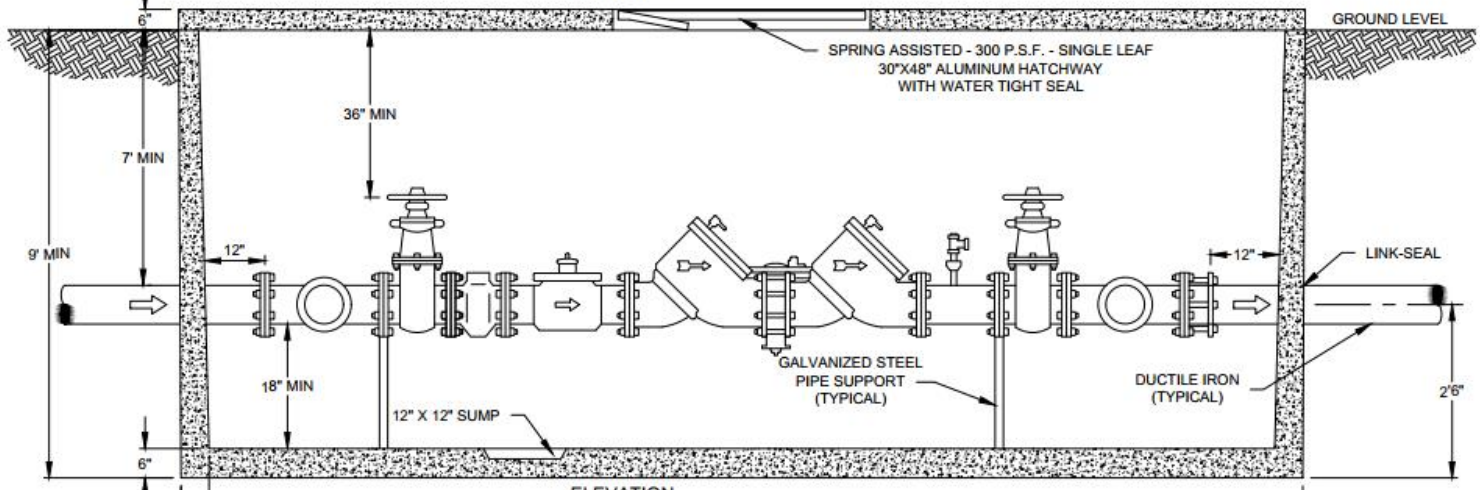

ELEVATION
SIZE DEPENDS ON PIPE USED AND EQUIPMENT

Issued: January, 2024

General Notes:

1. Fire service line and any domestic services branching from the fire service line are privately owned and maintained after the isolation valve.
2. Domestic service lines to have shutoff valves at or near the property line:
4" and larger service to install gate vales.
2" and smaller service to install curb stop.

**Commercial/Industrial
Meter Pit with Backflow Preventer and Valves Inside**

Watertown Municipal Utilities
901 4th Ave. SW
Watertown, S.D. 57201

Specification
Reference

Sheet
Number

Notes:

Backflow:

1. All assemblies shall be installed a minimum of 12 inches above the floor, from the lowest point of the assembly, and less than 60 inches above the floor from the highest point of the assembly. (30"-36" Ideal Height of Assembly)
2. A minimum of 12 inches of clear space shall be maintained above the assembly to allow for servicing check valves and for operation of shut-off valves. More distance will be required for larger assemblies.
3. A minimum of 30 inches of clear space shall be maintained between the front side of the assembly and the nearest wall or obstruction. More distance will be required for larger assemblies.
4. At least 12 inches clearance shall be maintained from the test cocks of the assembly to the nearest wall or obstruction.
5. Containment Backflow Preventers must be installed immediately following the water meter (or as close to as possible) and before any branch piping. PRVs must be installed after meter and backflow.
6. Assemblies must NOT be installed directly above, or where their operation, testing and maintenance may result in damage to the water meter. (unless otherwise approved in writing by the Water Division)
7. Multiple assemblies installed in a manifold or parallel manner shall not be installed one directly over another. Assemblies must be side by side or at a 45 degree angle and comply with all of the requirements in this section. (unless otherwise approved in writing by the Water Division)
8. Shut off valves on a backflow assembly from the factory are an integral part of the assembly and factor into the assemblies' approval. These shut offs DO NOT replace, and should not be designed or installed to be used as, the shut off for the service line to make repairs or for maintenance. An approved, separate shut off must be used in conjunction with the assembly.

Meters:

1. Without prior justification and approval by Watertown Municipal Utilities, water meters will no longer be installed in manholes or pits.
2. All meters and piping must be supported
3. No galvanized or steel materials allowed on a service ahead of the containment backflow preventer. All fittings and nipples on copper services must be brass or copper and must be flared or threaded NOT soldered, braised or "pro pressed".
4. Must maintain 30" of clearance in front of meter
5. MTU will be wired to meter for remote reading
6. Irrigation meters will be tee'd before the domestic meter (no sewer charge)

The Water Division must be called to have the water meter set once all construction activities and all piping, including both inlet and outlet sides of the water meter, is finished.

Water Meter Shutoff Valves

Water meter shutoff valve types shall be as follows:

- Shutoff valves 1" in diameter or less shall be a ball valve.
- Shutoff valves 1.5" in diameter shall be a full flow gate valve or ball valve.
- Shutoff valves 2" in diameter shall be a full flow gate valve.

Water Meter Lay Lengths

Positive Displacement (Meter and Meter Connections)	Ultrasonic (Meter and Meter Connections)	Compound (Meter Only)
5/8" METER=12.5"	1-1/2" METER=15.5"	3" METER=17"
3/4" METER=14.75"	2" METER=19.5"	4" METER=20"
1" METER=16.5"		6" METER=24"
1-1/2" METER=15.5"		
2" METER=19.5"		

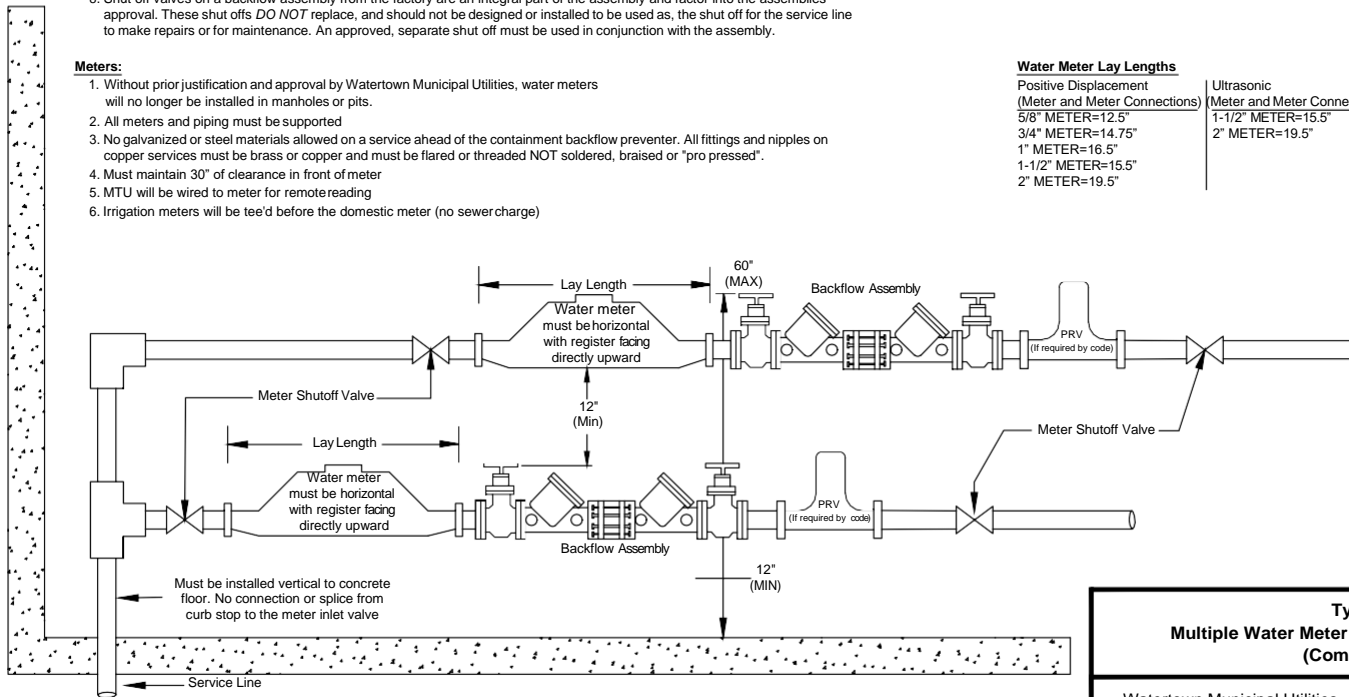

Issued: December, 2022

Typical Multiple Water Meter & Backflow Installation (Commercial)		
Watertown Municipal Utilities 901 4th Ave. SW Watertown, S.D. 57201	Specification Reference	Sheet Number

Notes:

Backflow:

1. All assemblies shall be installed a minimum of 12 inches above the floor, from the lowest point of the assembly, and less than 60 inches above the floor from the highest point of the assembly. (30"-36" Ideal Height of Assembly)
2. A minimum of 12 inches of clear space shall be maintained above the assembly to allow for servicing check valves and for operation of shut-off valves. More distance will be required for larger assemblies.
3. A minimum of 30 inches of clear space shall be maintained between the front side of the assembly and the nearest wall or obstruction. More distance will be required for larger assemblies.
4. At least 12 inches clearance shall be maintained from the test cocks of the assembly to the nearest wall or obstruction.
5. Containment Backflow Preventers must be installed immediately following the water meter (or as close to as possible) and before any branch piping. PRVs must be installed after meter and backflow.
6. Assemblies must NOT be installed directly above, or where their operation, testing and maintenance may result in damage to the water meter. (unless otherwise approved in writing by the Water Division)
7. Multiple assemblies installed in a manifold or parallel manner shall not be installed one directly over another. Assemblies must be side by side or at a 45 degree angle and comply with all of the requirements in this section. (unless otherwise approved in writing by the Water Division)
8. Shut off valves on a backflow assembly from the factory are an integral part of the assembly and factor into the assemblies' approval. These shut offs DO NOT replace, and should not be designed or installed to be used as, the shut off for the service line to make repairs or for maintenance. An approved, separate shut off must be used in conjunction with the assembly.

The Water Division must be called to have the water meter set once all construction activities and all piping, including both inlet and outlet sides of the water meter, is finished.

Water Meter Shutoff Valves

Water meter shutoff valve types shall be as follows:
 Shutoff valves 1" in diameter or less shall be a ball valve.
 Shutoff valves 1.5" in diameter shall be a full flow gate valve or ball valve.
 Shutoff valves 2" in diameter shall be a full flow gate valve.

Meters:

1. Without prior justification and approval by Watertown Municipal Utilities, water meters will no longer be installed in manholes or pits.
2. All meters and piping must be supported
3. No galvanized or steel materials allowed on a service ahead of the containment backflow preventer. All fittings and nipples on copper services must be brass or copper and must be flared or threaded NOT soldered, braised or "pro pressed".
4. Must maintain 30" of clearance in front of meter
5. MTU will be wired to meter for remote reading
6. Irrigation meters will be tee'd before the domestic meter (no sewer charge)

Water Meter Lay Lengths

Positive Displacement (Meter and Meter Connections)	Ultrasonic (Meter and Meter Connections)	Compound (Meter Only)
5/8" METER=12.5"	1-1/2" METER=15.5"	3" METER=17"
3/4" METER=14.75"	2" METER=19.5"	4" METER=20"
1" METER=16.5"		6" METER=24"
1-1/2" METER=15.5"		
2" METER=19.5"		

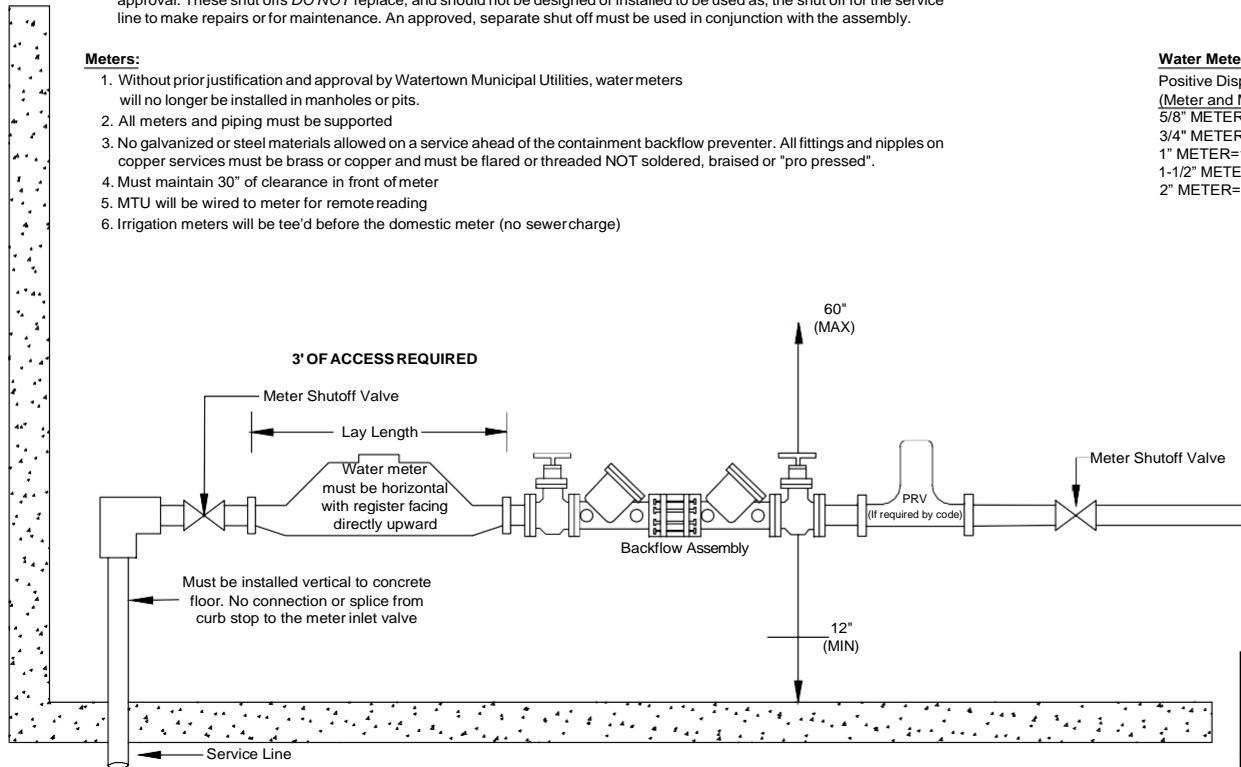

Issued: December, 2022

Typical Single Water Meter & Backflow Installation (Commercial)		
Watertown Municipal Utilities 901 4th Ave. SW Watertown, S.D. 57201	Specification Reference	Sheet Number 3 of 43

Concrete Thrust Blocks

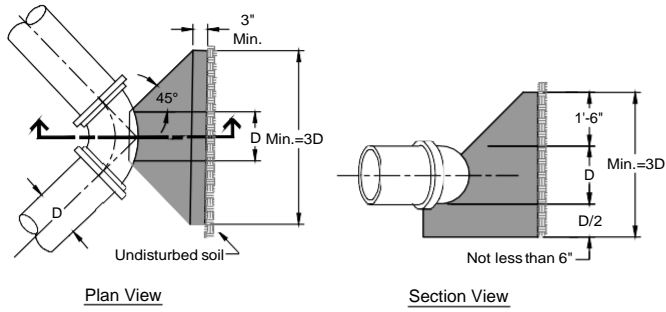

90 - Degree Bend

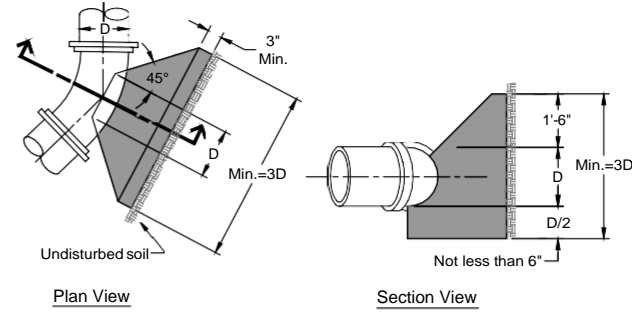

11 1/4 - Degree, 22 1/2 - Degree and 45 - Degree Bends

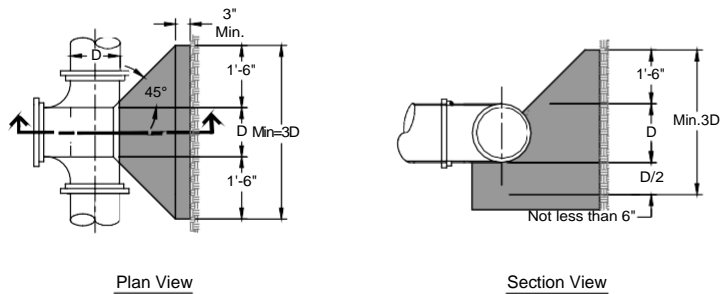

Tee

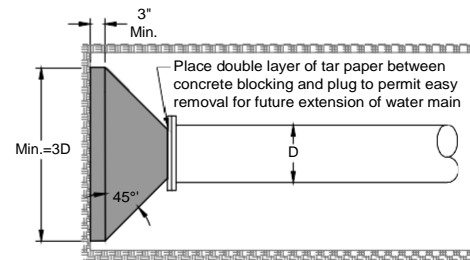

S.J./M.J. Plug

Issued: December, 2022

Concrete Thrust Blocks		
Watertown Municipal Utilities 901 4th Ave. SW Watertown, S.D. 57201	Specification Reference	Sheet Number

Notes:

- 1 Riser Pipe: Ductile iron flange and spigot through the slab or wall, 6" dia. minimum unless approved by Watertown Fire Marshal
- 2 Fire Service Line: Minimum 6" dia. unless approved by Watertown Fire Marshal
- 3 Riser Fitting: MJ 90° Bend or MJ Tee. Thrust blocking per NFPA 24 to undisturbed soil.
- 4 Redi Rod & Tie Bolts: Riser pipe rodded together (2 ea)
Corrosion Resistance: Corten Weathering Steel Alloy or approved equal
Strength: Grade 10
Installation: per NFPA 24
5. System Riser

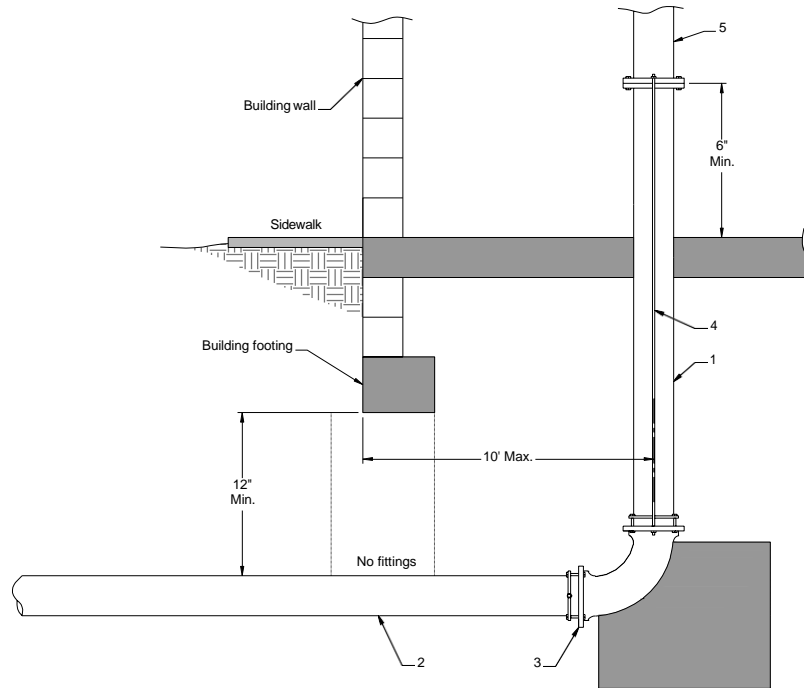

Issued: December, 2022

Fire Service Riser		
Watertown Municipal Utilities 901 4th Ave. SW Watertown, S.D. 57201	Specification Reference	Sheet Number

Hydrant Connection

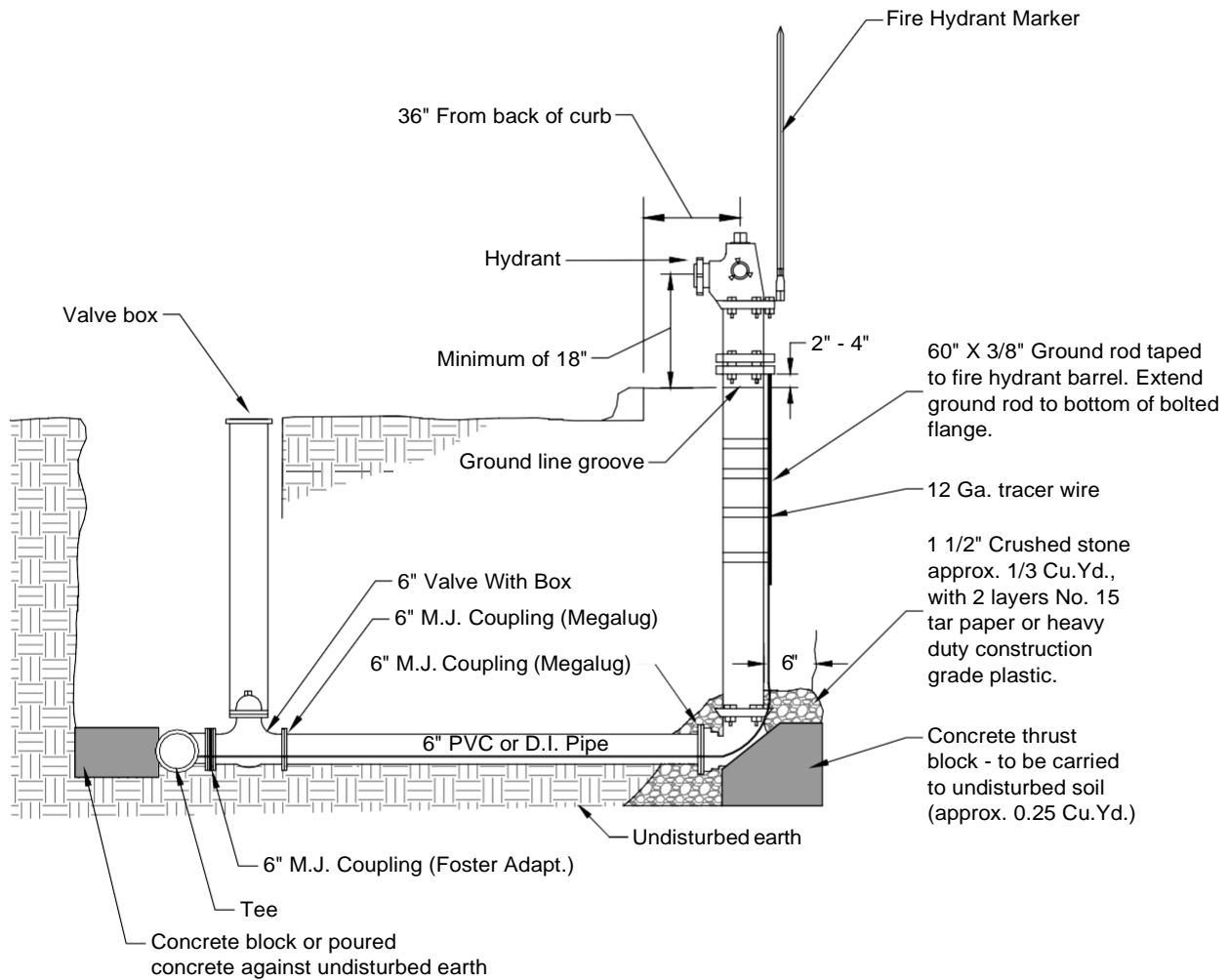

General Notes:

1. Hydrant grade to be shown on plans.
2. Valve on fire hydrant lateral shall be restrained.
3. All exposed pipe joints shall be restrained on hydrant lateral.
4. Install V-bio polywrap on fire hydrant barrel to the ground surface before installing tracer wire system. Do not cover weep holes with polywrap.

Issued: December, 2022

Watertown Municipal Utilities
901 4th Ave. SW
Watertown, S.D. 57201

Hydrant Connection

Specification
Reference

Sheet
Number

MACHINE SLICED HIGH FLOW SILT FENCE INSTALLATION

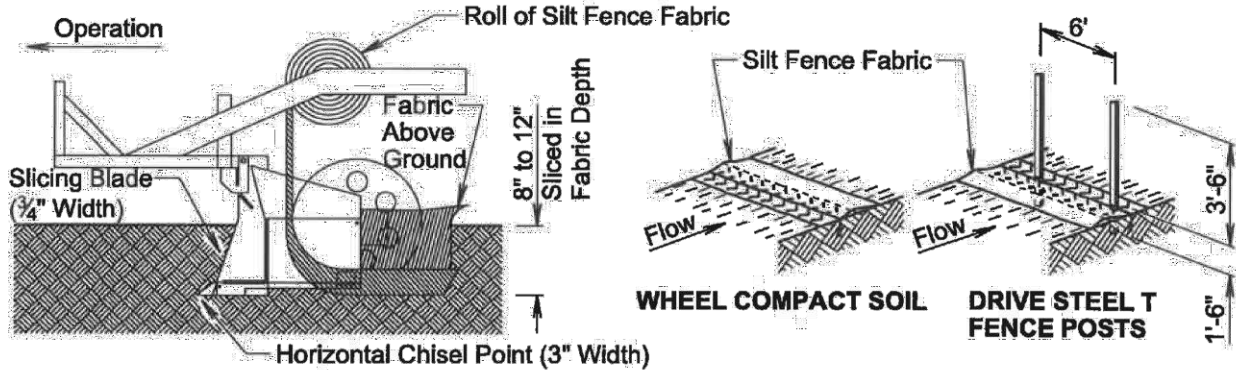

① **INSTALL SILT FENCE FABRIC BY MACHINE SLICING METHOD.**

② **WHEEL COMPACT SOIL ABOVE SLICED IN PORTION OF FABRIC AND THEN DRIVE STEEL T FENCE POSTS.**

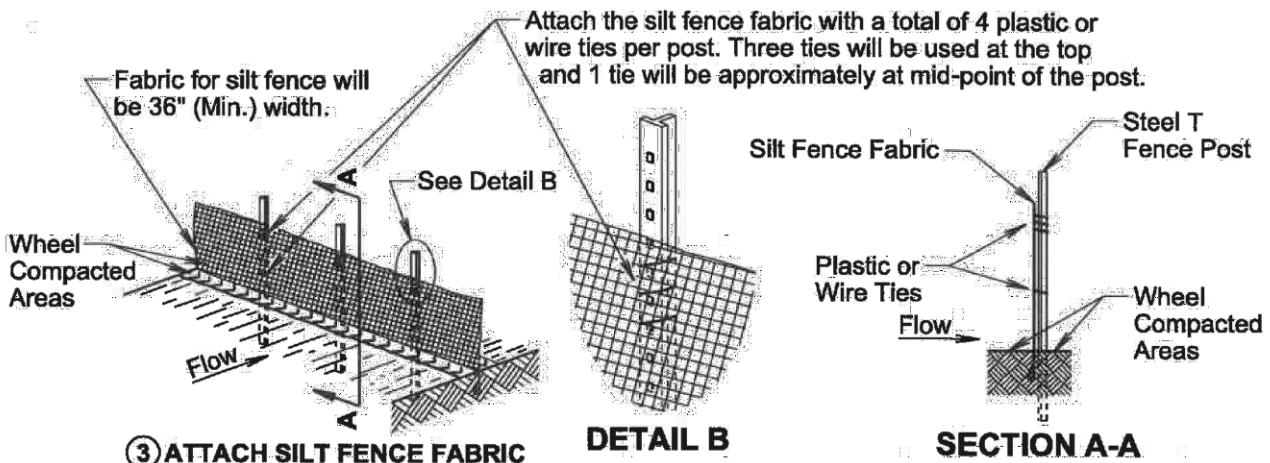

③ **ATTACH SILT FENCE FABRIC**

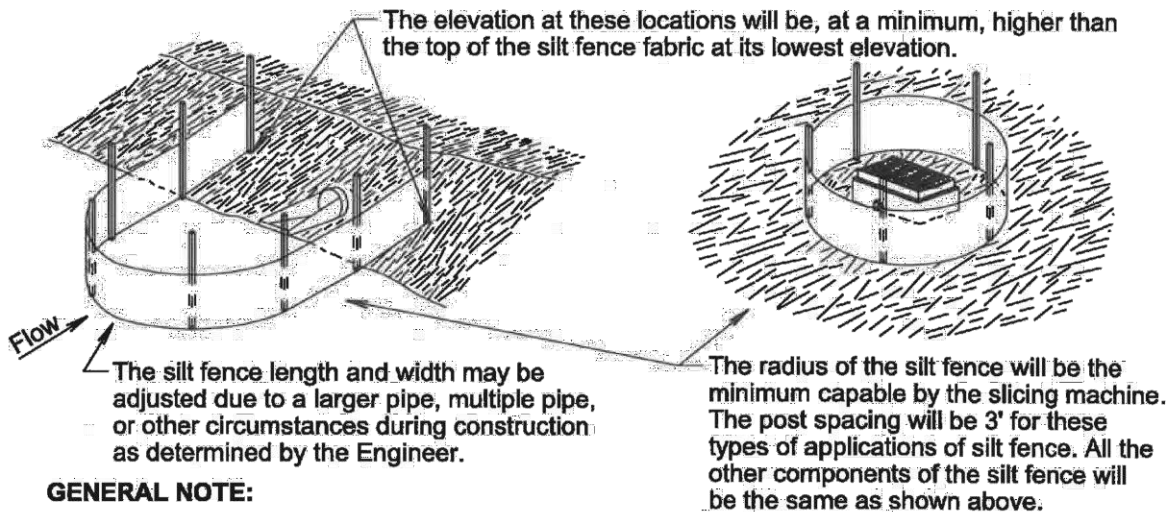

GENERAL NOTE:

If a trench can not be dug or the silt fence fabric can not be sliced in due to the type of earthen material (such as rock), then a row of 30 to 40 pound sandbags butted end to end will be provided on top of the extra length of silt fence fabric to prevent underflow.

Issued: December, 2022

Watertown Municipal Utilities 901 4th Ave. SW Watertown, S.D. 57201	Machine Sliced High Flow Silt Fence	Specification Reference	Sheet Number
---	--	----------------------------	-----------------

MACHINE SLICED LOW FLOW SILT FENCE INSTALLATION

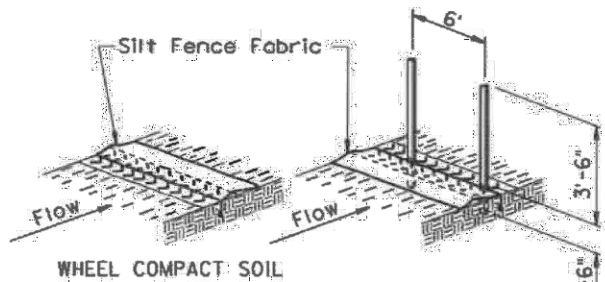
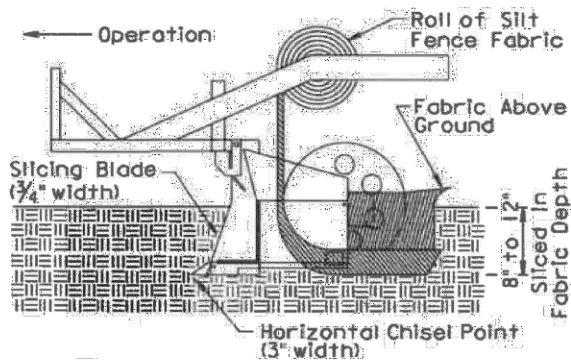

DRIVE STEEL T FENCE POSTS

- ① INSTALL SILT FENCE FABRIC BY MACHINE SLICING METHOD.

Silt fence fabric shall be overlapped a minimum of 2" at top of woven wire fence.

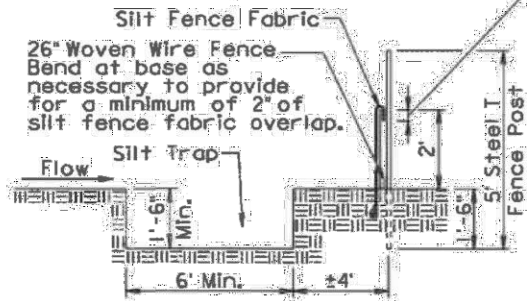

- ② WHEEL COMPACT SOIL ABOVE SLICED IN PORTION OF FABRIC AND THEN DRIVE STEEL T FENCE POSTS.

Attach the silt fence fabric with plastic ties, wire ties, or hog rings at 12" max. horizontal spacing on the top and bottom wires of the woven wire fence and with plastic or wire ties at 12" max. vertical spacing on the posts.

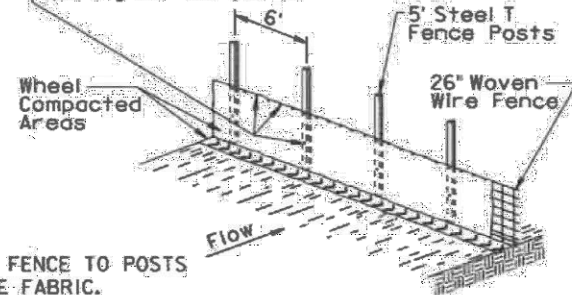

- ③ ATTACH 26" WOVEN WIRE FENCE TO POSTS AND ATTACH SILT FENCE FABRIC.

The elevation at these locations shall be, at a minimum, higher than the top of the silt fence fabric at its lowest elevation.

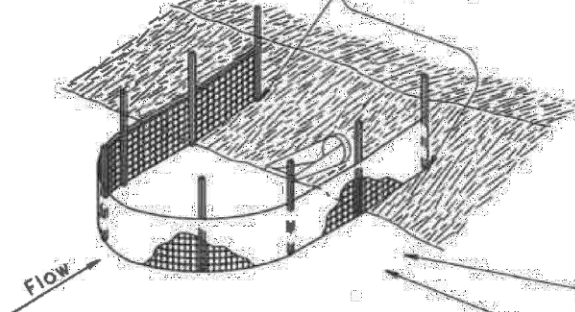

The silt fence length and width may be adjusted due to a larger pipe, multiple pipe, or other circumstances during construction as determined by the Engineer.

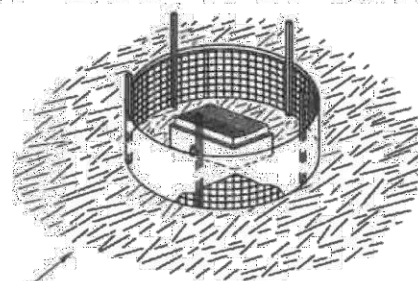

The radius of the silt fence shall be the minimum capable by the slicing machine. The post spacing shall be 3' for these types of applications of silt fence. All the other components of the silt fence shall be the same as shown above.

GENERAL NOTES:

A silt trap shall be provided when specified by a plan note. All costs for constructing the silt trap shall be incidental to the contract unit price per cubic yard for "Silt Trap".

If a trench can not be dug or the silt fence fabric can not be sliced in due to the type of earthen material (such as rock), then a row of 30 to 40 pound sandbags buffed end to end shall be provided on top of the extra length of silt fence fabric to prevent underflow.

Issued: December, 2022

Watertown Municipal Utilities
901 4th Ave. SW
Watertown, S.D. 57201

**Machine Sliced Low Flow
Silt Fence**

Specification
Reference

Sheet
Number

MANUAL HIGH FLOW SILT FENCE INSTALLATION

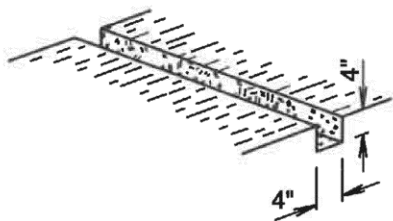

① EXCAVATE TRENCH

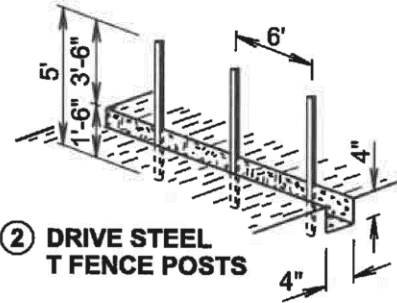

② DRIVE STEEL T FENCE POSTS

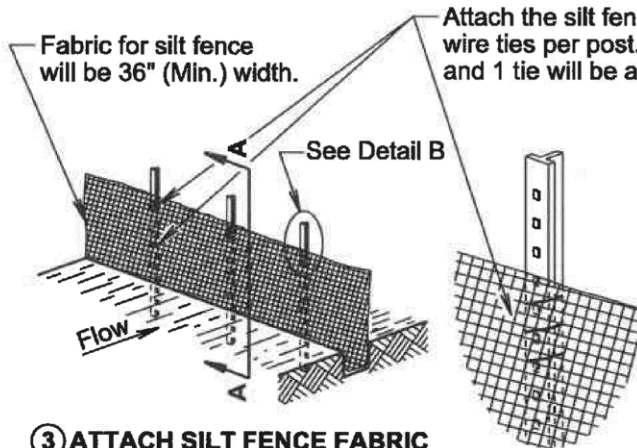

③ ATTACH SILT FENCE FABRIC

Attach the silt fence fabric with a total of 4 plastic or wire ties per post. Three ties will be used at the top and 1 tie will be approximately at mid-point of the post.

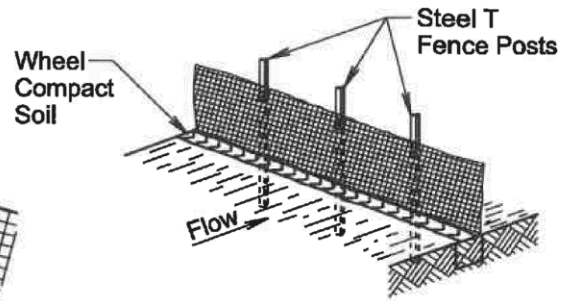

④ BACKFILL TRENCH AND WHEEL COMPACT SOIL

DETAIL B

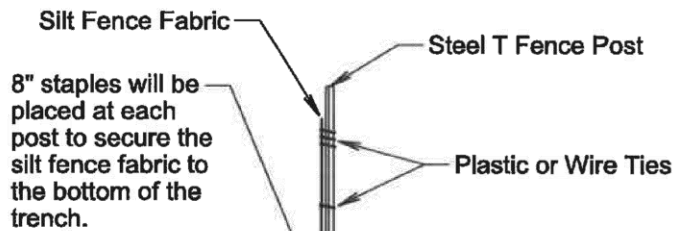

8" staples will be placed at each post to secure the silt fence fabric to the bottom of the trench.

The elevation at these locations will be, at a minimum, higher than the top of the silt fence fabric at its lowest elevation.

SECTION A-A

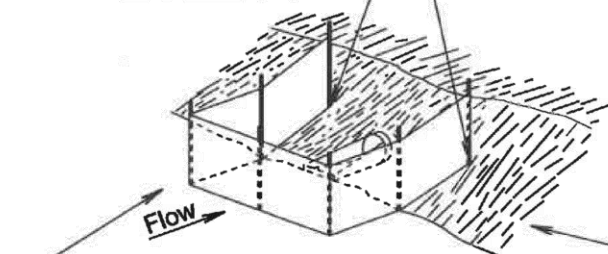

The silt fence length and width may be adjusted due to a larger pipe, multiple pipe, or other circumstances during construction as determined by the Engineer.

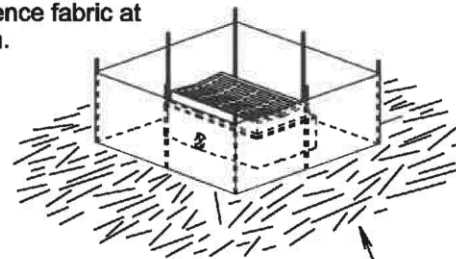

Post spacing will be 3' for these types of applications of silt fence. All other components of the silt fence will be the same as shown above.

Issued: December, 2022

Watertown Municipal Utilities 901 4th Ave. SW Watertown, S.D. 57201	Manual High Flow Silt Fence	Specification Reference	Sheet Number
---	--	----------------------------	-----------------

MANUAL LOW FLOW SILT FENCE INSTALLATION

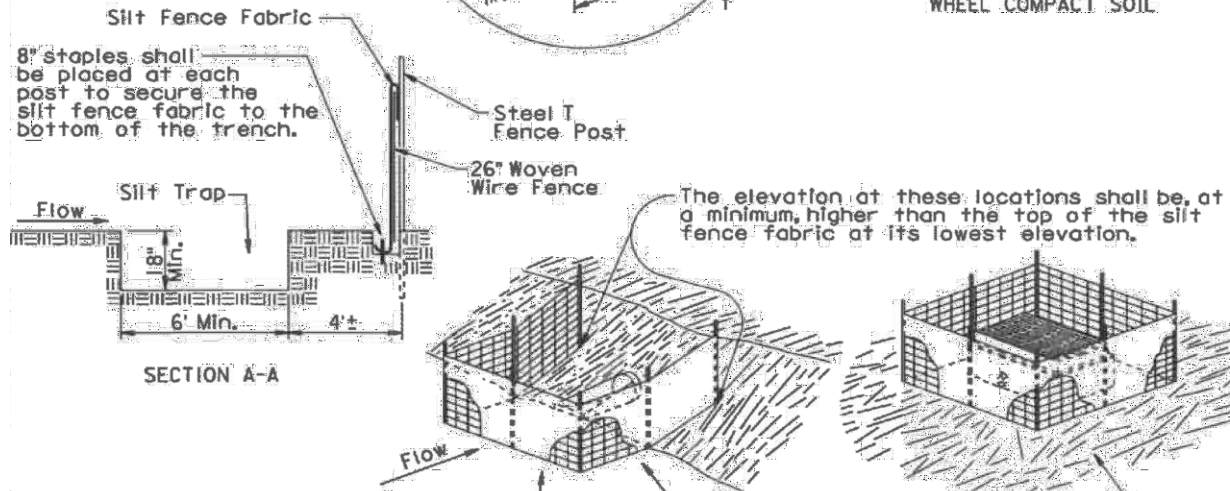
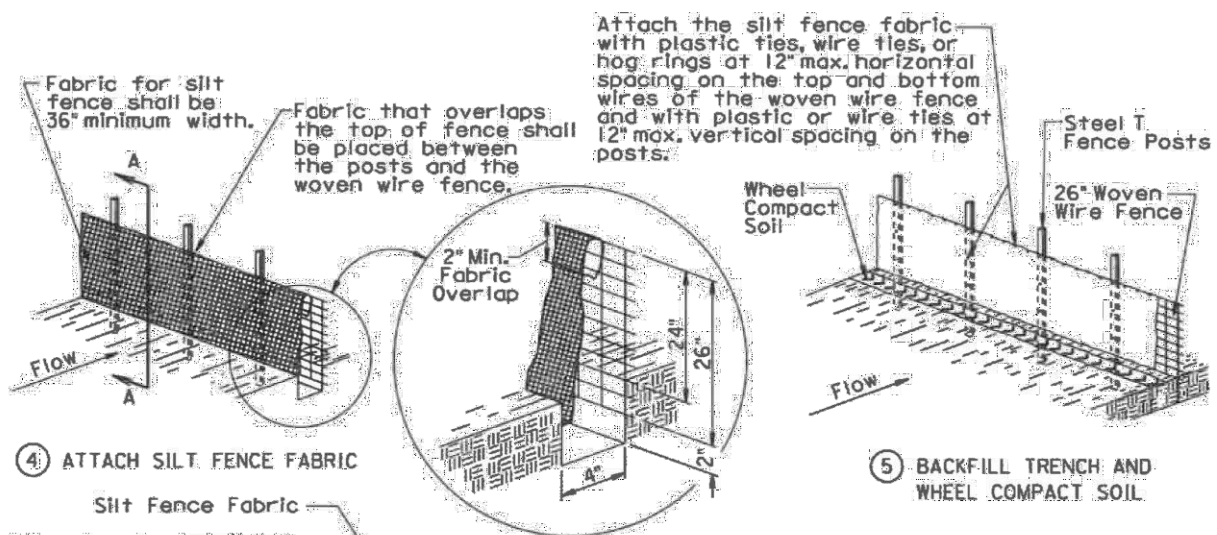
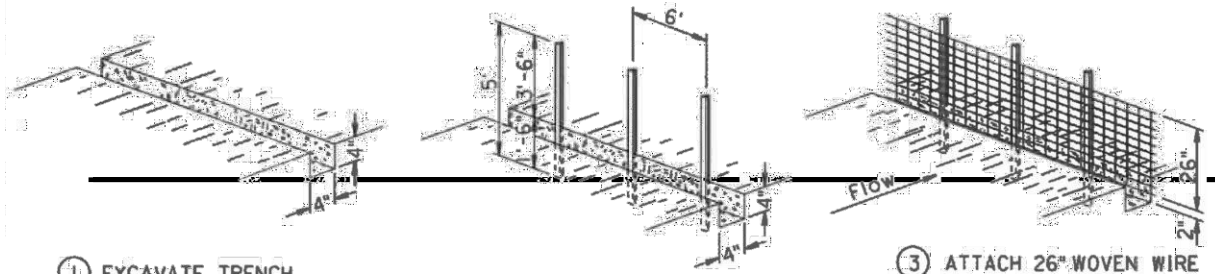

The silt fence length and width may be adjusted due to a larger pipe, multiple pipe, or other circumstances during construction as determined by the Engineer.

Post spacing shall be 3' for these types of applications of silt fence. All other components of the silt fence shall be the same as shown above.

Issued: December, 2022

Watertown Municipal Utilities
901 4th Ave. SW
Watertown, S.D. 57201

**Manual Low Flow
Silt Fence**

Specification
Reference

Sheet
Number

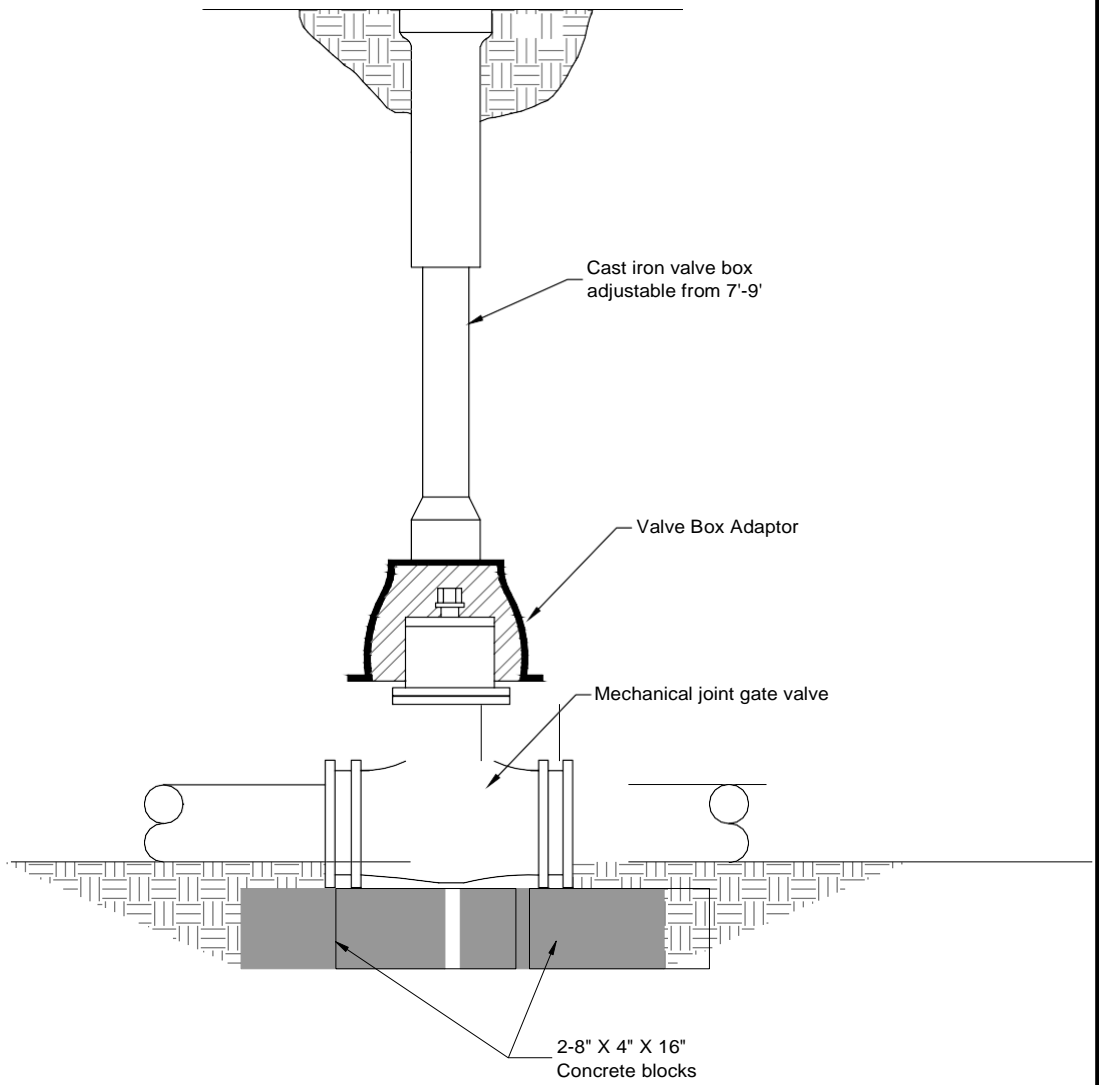

**PVC Pipe Gate Valve
Installation**

Not to scale

Issued: December, 2022

<p>Watertown Municipal Utilities 901 4th Ave. SW Watertown, S.D. 57201</p>	<p>PVC Gate Valve Installation</p>	<p>Specification Reference</p>	<p>Sheet Number</p>
--	---	------------------------------------	-------------------------

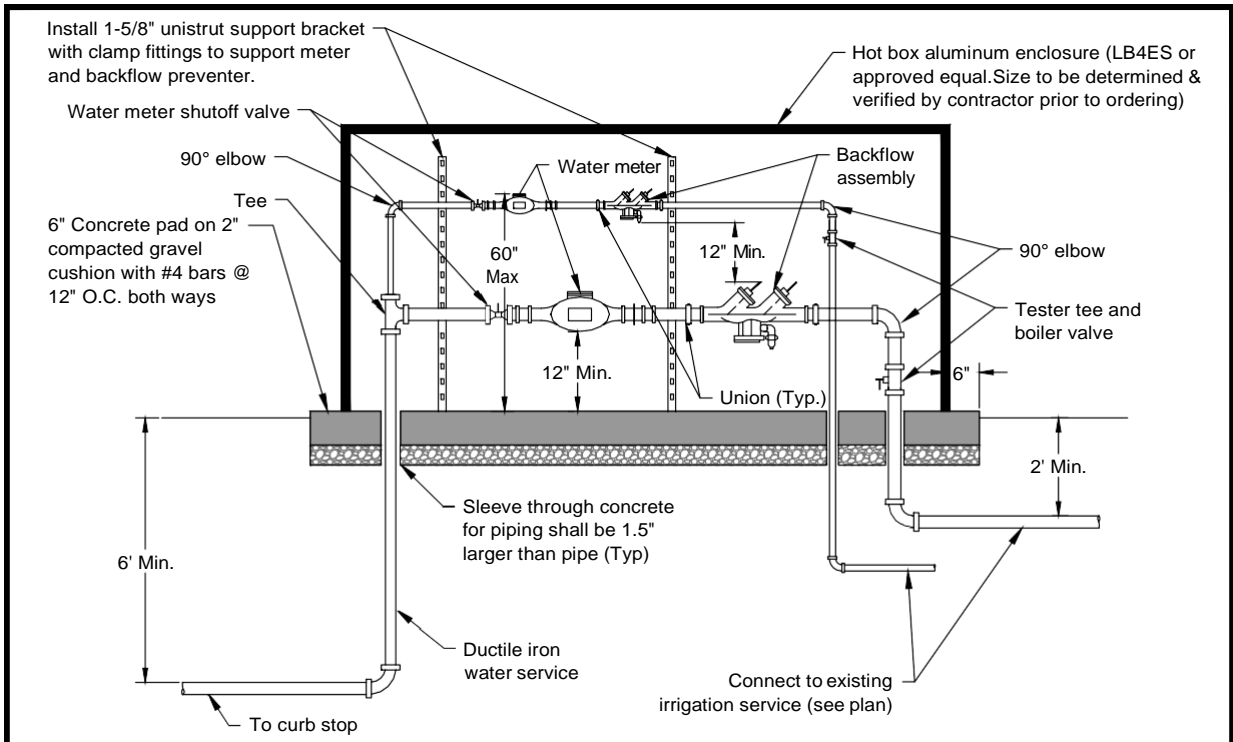

General Notes:

1. All enclosures are to be installed and connected onto a concrete base per manufacturer's recommendations and as detailed above.
2. All backflow assemblies shall be tested by a City approved, ABPA certified backflow technician prior to being put into service.
3. Backflow will be removed by owner during winterization procedures and stored. Install accordingly to allow annual removal.
4. Concrete pad to be constructed with class M6 concrete.
5. Submit shop drawings for approval of aluminum enclosure. Contractor is responsible for providing size recommendations to ensure 12" of interior clearance around all piping and equipment
6. All piping and fittings inside enclosure for irrigation service to 2 feet outside enclosure shall conform to city ordinance and engineering design standards.
7. Keep meters and backflow assemblies centered (L&R) in enclosure.
8. For assemblies 3/4" - 2", Wilkins 375XL RP or the Wilkins 350XL DC shall be used.
9. All costs associated with construction of the water service from the shutoff valve, through the meter and backflow enclosure, to the PVC irrigation mainline connection shall be included in the unit price per each of "Meter and Backflow Enclosure"
10. The meter, backflow preventer and misc. pipe and fittings shall be enclosed as detailed above.
11. All costs associated with construction of the meter and backflow enclosure, including, the enclosure, concrete base, rebar and misc. Hardware shall be included in the unit price per each of "Meter and Backflow Enclosure."
12. All costs associated with meter and backflow enclosure piping from the curb stop to 24" outside the enclosure for the irrigation service shall be included in the unit per each bid item "Meter and Backflow Enclosure."
13. Water Department approval of meter and backflow
14. Building Services standard approval requirements apply.
15. Multiple assemblies installed in manifold or parallel manner shall not be installed one directly over another. Multiple assemblies must be side by side, staggered, or at a 45° angle and comply with all of the requirements in this section. (Unless otherwise approved in writing by the Water Division.)

Issued: December, 2022

<p>Watertown Municipal Utilities 901 4th Ave. SW Watertown, S.D. 57201</p>	<p>Staggered Water Meter & Backflow Dual Assembly with Enclosure</p>	<p>Specification Reference</p>	<p>Sheet Number</p>
--	---	------------------------------------	-------------------------

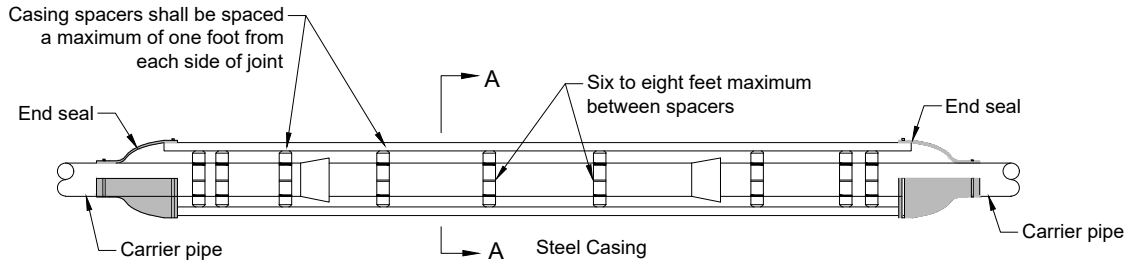

Elevation

Casing spacers and end seals shall be manufactured by Advanced Products and Systems, Inc. P.O. Box 60399 Lafayette, LA. 70596-0399 or equal and meet these requirements.

Casing Spacers - Model SSI-8 (Pipe sizes 24 inches in diameter and smaller) or Model SSI-12-2 (pipe sizes 30 inches in diameter and greater) with T-304 stainless steel spacer.

Band - 10 Gauge T-304 stainless steel.
Riser - 10 Gauge T-304 stainless steel.

Runners - Two inch wide minimum glass reinforced plastic. The number of risers shall be as recommended by the manufacturer, but four is the minimum.

Studs, Nuts and Washers - T-304 stainless steel.

Heights - As required for center restraining

End Seals - Conical shaped wrap-around 1/8 inch rubber with T-304 stainless steel straps.

Casing pipe must conform to ASTM A53 grade B minimum yield strength of 35,000 pounds per square inch.

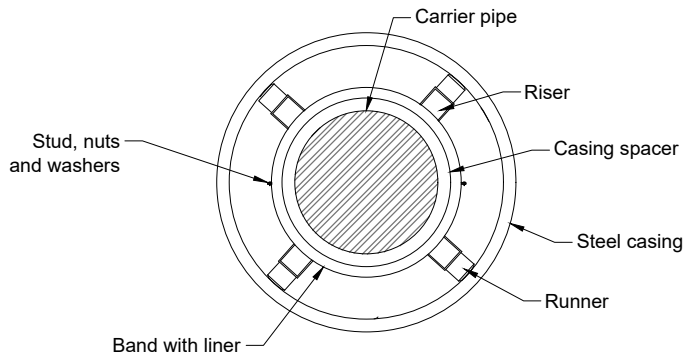

Section A-A

Pipe Size	Casing Size
4"	10"
6"	12"
8"	16"
10"	18"
12"	20"
16"	24"
20"	30"
24"	36"
30"	42"
>36"	*

*As recommended by manufacturer

Issued: December, 2022

Watertown Municipal Utilities 901 4th Ave. SW Watertown, S.D. 57201	Standard Casing/Carrier for Water Pipe	Specification Reference	Sheet Number
---	--	----------------------------	-----------------

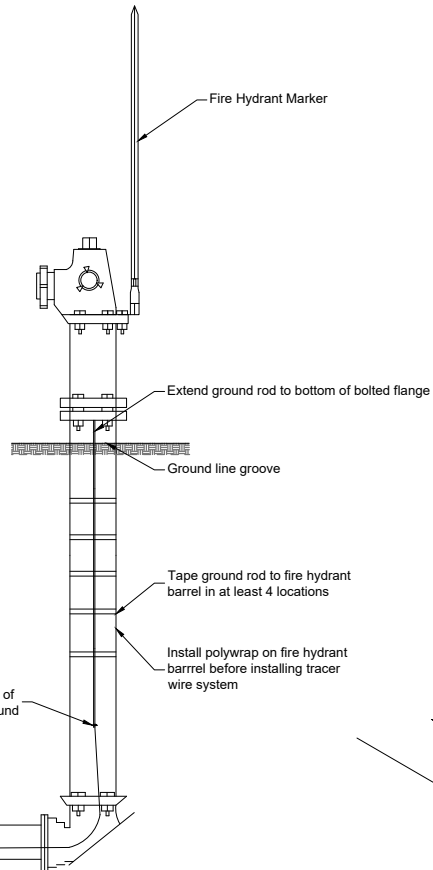

Tracer Wire Detail at Fire Hydrant
Not to scale

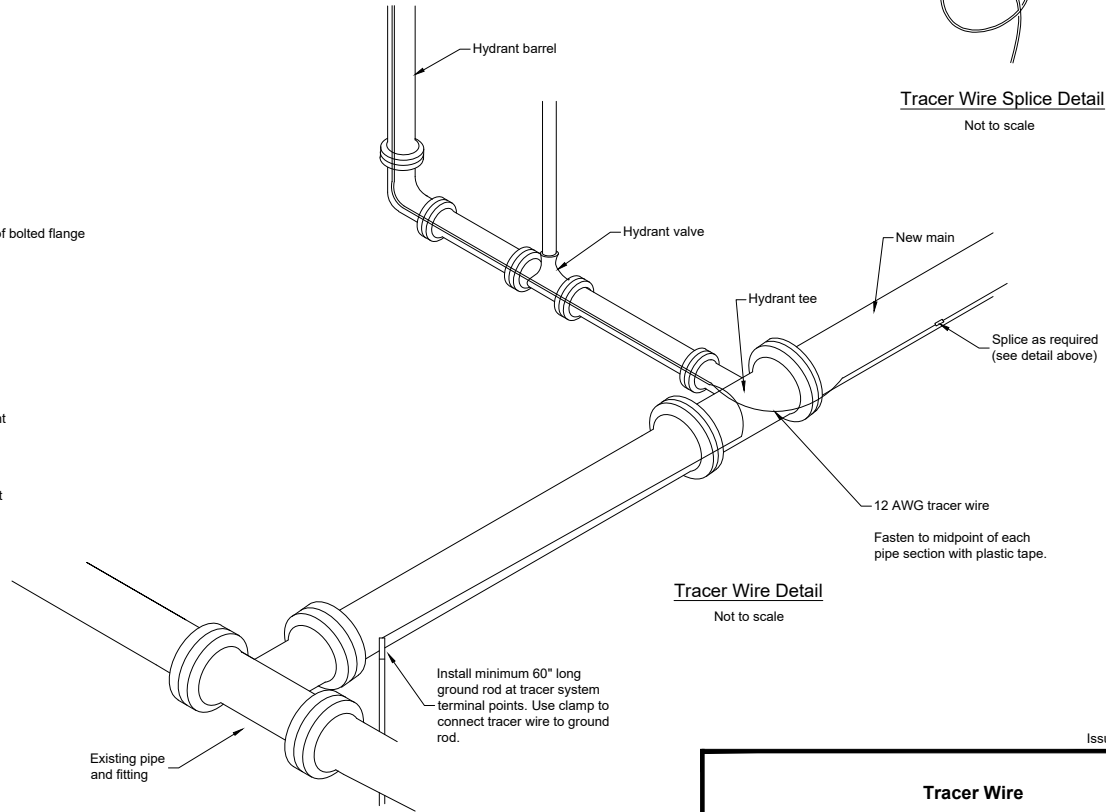

Tracer Wire Detail
Not to scale

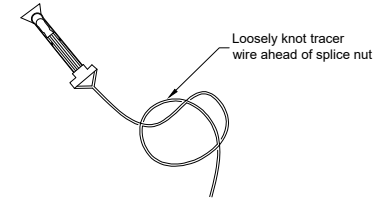

Tracer Wire Splice Detail
Not to scale

Issued: December, 2022

Tracer Wire		
Watertown Municipal Utilities 901 4th Ave. SW Watertown, S.D. 57201	Specification Reference	Sheet Number

Valve Box Adjustment

Spin Up Method

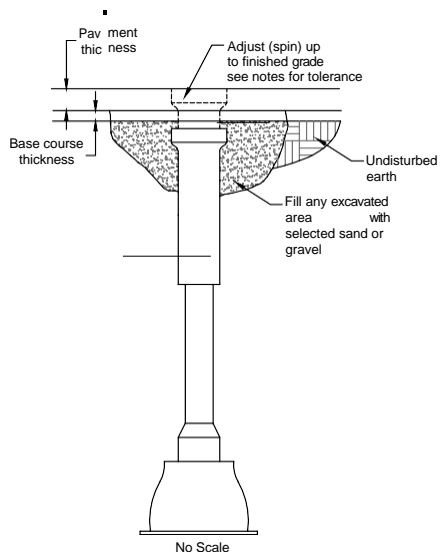

Spin Up Method:

1. Use this method if top section of valve box can be adjusted to finished grade.
2. If the 0" to 1/2" tolerance cannot be met by the "spin up" method on asphalt streets, then the contractor shall be required to adjust the valve box by the circular cutout method. This additional work, if required, shall be incidental to the "valve box adjustment" bid item.
3. If the 0" to 1/2" tolerance can not be met by the "spin up" method on concrete streets, the repair method will be determined by the engineer. This additional work shall be incidental to the "valve box adjustment" bid item.
4. If the valve box needs minor adjustment, a minimal amount of heat can be applied to break the bond between the valve box and the asphalt. Full depth heating of the asphalt will not be allowed. If the asphalt appears to show signs of deterioration, it will be at the discretion of the engineer to require the cut out method.

Cutout Method

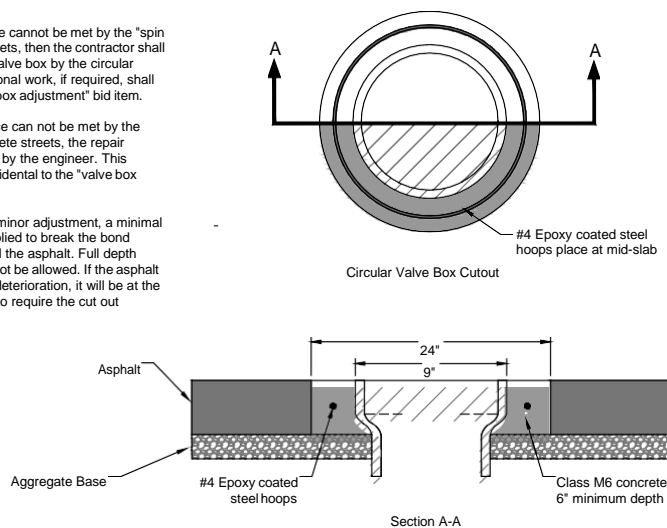

Cut Out Method:

1. The circular concrete cutout shall be centered on the valve box frame.
2. The circular concrete cutout shall be constructed after the installation of the top lift of asphalt. The pavement shall be sawed full depth with a vertical face. The contractor shall ensure that the adjacent asphalt surface is left intact and undamaged when removing the circular cutout.
3. The circular concrete cutout diameter shall be 24".
4. Apply tack coat to the vertical asphalt surfaces prior to placement of concrete cutout.
5. Class M6 concrete shall be used for the cutout. Fast track concrete may be used at the discretion of the engineer.
6. Steel reinforcing shall be epoxy coated grade 40.
7. Steel reinforcing shall consist of #4 hoops (variable length) supported by approved chairs.
8. Maintain a minimum of 2" clearance on all steel reinforcing.
9. All work associated with constructing the circular concrete cutout, including, but not limited to: all materials, sawing, steel reinforcing, chairs, concrete, labor, tools, removal and replacement, excavation and backfilling and other appurtenances shall be incidental to the "valve box adjustment" bid item.

General Notes:

1. Non-threaded adjustments will not be allowed.
2. Plumb valve box prior to backfilling. All valve boxes shall be adjusted to be flush with the pavement surface prior to placement of the pavement surfacing. The allowable vertical tolerance between the pavement surface and any part of the valve box shall be 0" to 1/2" low. In no case shall the valve box be above the surface of the pavement.
3. It shall be the contractor's responsibility to provide a system to prevent material from entering the valve box during the work.
4. All adjustments shall be completed prior to opening up the street to traffic.

Issued: December, 2022

Valve Box Adjustment

Watertown Municipal Utilities
901 4th Ave. SW
Watertown, S.D. 57201

Specification
Reference

Sheet
Number

Valve Box Extension
(or replacement of top section)

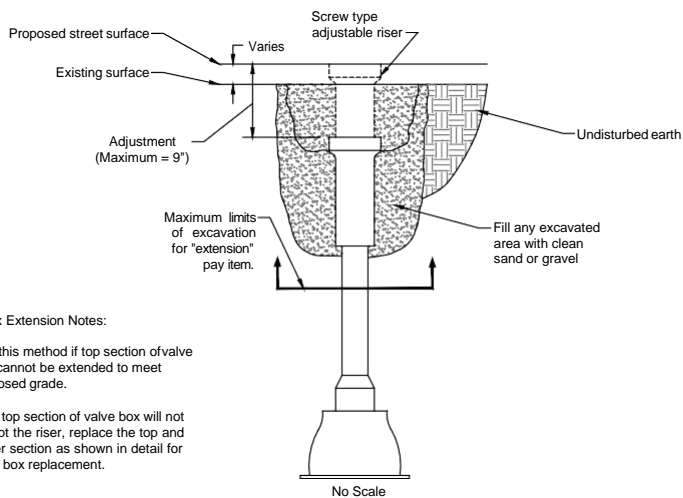

Valve Box Extension Notes:

1. Use this method if top section of valve box cannot be extended to meet proposed grade.
2. If the top section of valve box will not accept the riser, replace the top and center section as shown in detail for valve box replacement.

General Notes:

1. Non-threaded adjustments will not be allowed.
2. Plumb valve box prior to backfilling. All valve boxes shall be adjusted to be flush with the pavement surface prior to placement of the pavement surfacing. The allowable vertical tolerance between the pavement surface and any part of the valve box shall be 0" to 1/2" low. In no case shall the valve box be above the surface of the pavement.
3. It shall be the contractor's responsibility to provide a system to prevent material from entering the valve box during the work.
4. All adjustments shall be completed prior to opening up the street to traffic.

Valve Box Installation

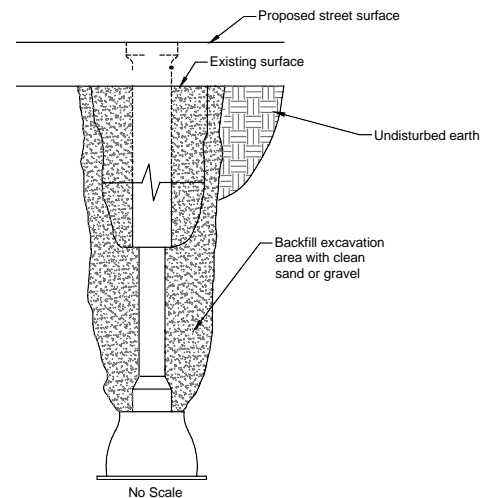

Issued: December, 2022

Valve Box Installation and Extension

Watertown Municipal Utilities
901 4th Ave. SW
Watertown, S.D. 57201

Specification
Reference

Sheet
Number

Water Main Adjustment

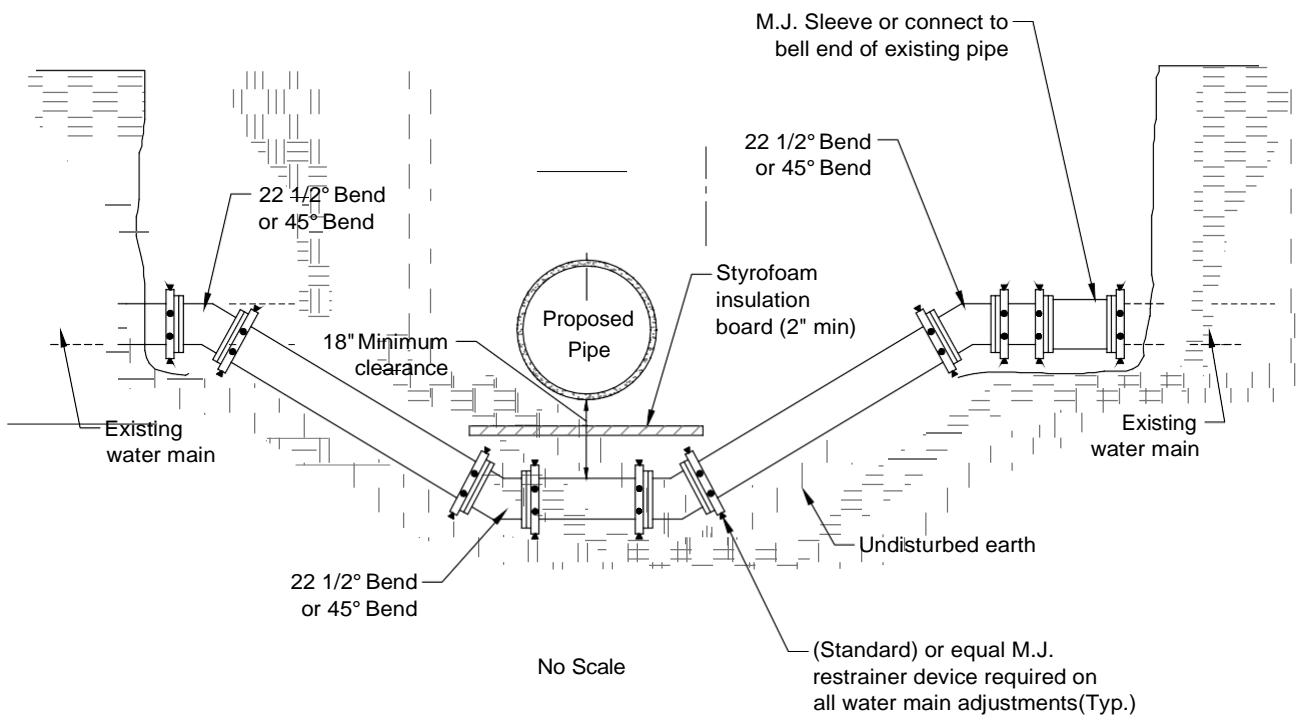

General Notes :

1. The pipe, fittings and restrainer devices shall be bid as separate items from the water main adjustment.
2. All exposed pipe joints shall be restrained

Issued: December, 2022

Watertown Municipal Utilities 901 4th Ave. SW Watertown, S.D. 57201	Water Main Adjustment	Specification Reference	Sheet Number
---	------------------------------	-------------------------	--------------

Water Main Bedding

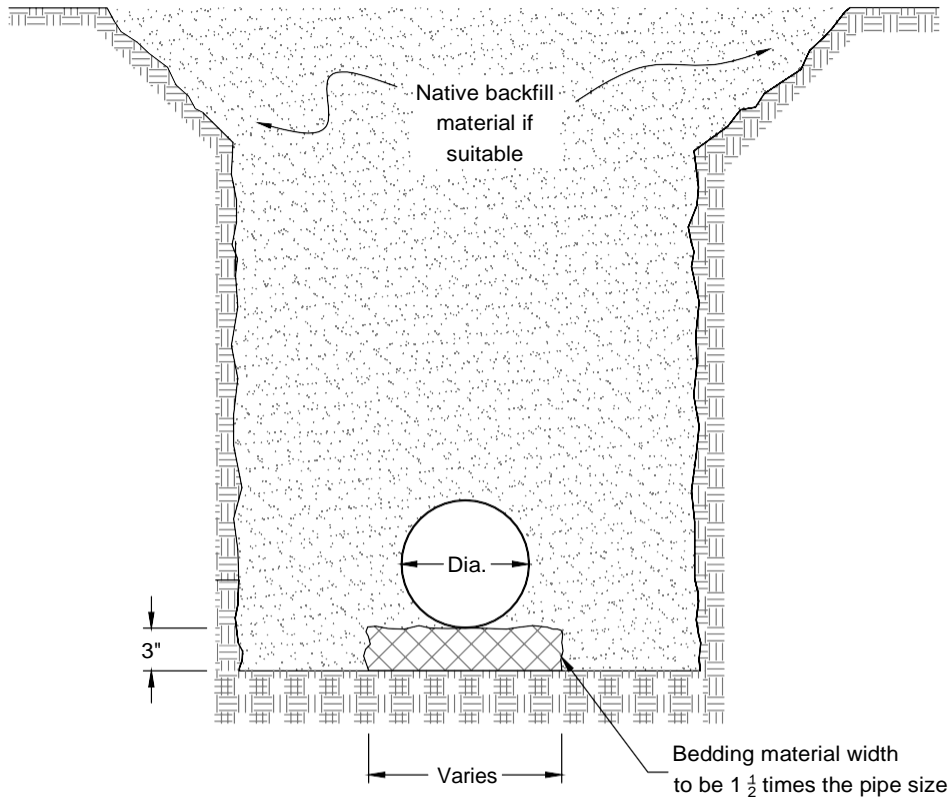

Pipe Size Diameter	Bedding Thickness	Bedding Width 1.5 x Pipe	Water Main Bedding Mat. Area	Water Main Bedding Mat. #s/LF
4"	3"	6"	.125 Sq.Ft.	17.50
6"	3"	9"	.1875 Sq.Ft.	26.25
8"	3"	12"	.25 Sq.Ft.	35.00
10"	3"	15"	.3325 Sq.Ft.	46.55
12"	3"	18"	.375 Sq.Ft.	52.50
16"	3"	24"	.50 Sq.Ft.	70.00
20"	3"	30"	.625 Sq.Ft.	87.50
24"	3"	36"	.75 Sq.Ft.	105.00
30"	3"	45"	.9375 Sq.Ft.	131.25

* Length based on one (1) foot of main.

Issued: December, 2022

Watertown Municipal Utilities
901 4th Ave. SW
Watertown, S.D. 57201

**Water Main Bedding
And Trench Backfill**

Specification
Reference

Sheet
Number

Water Main Bedding

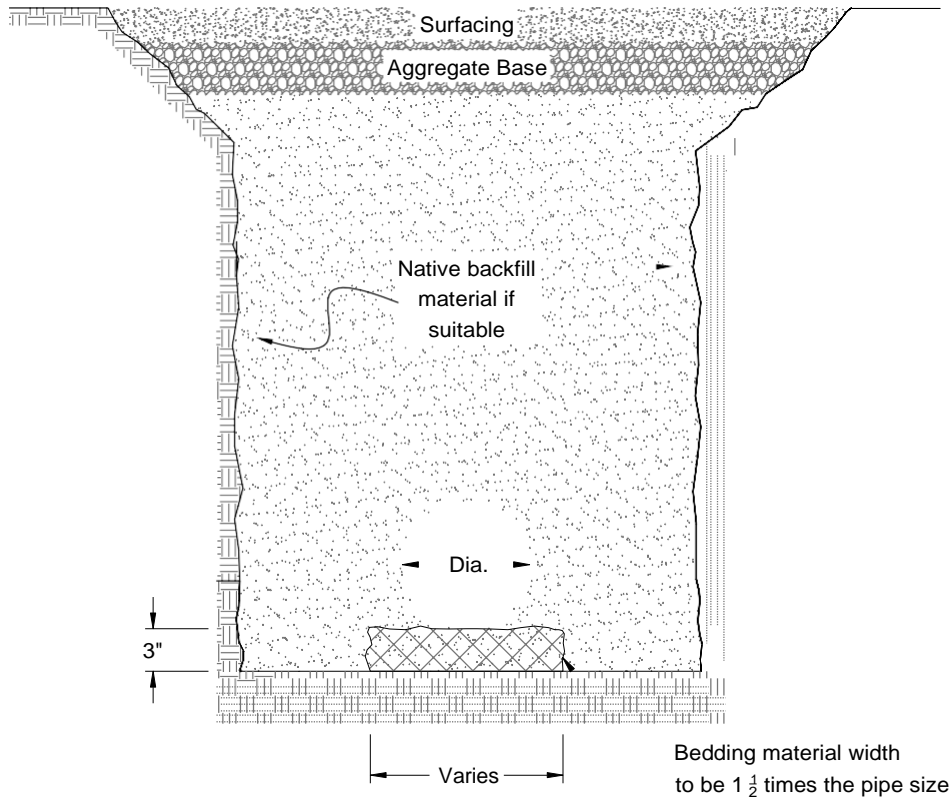

Pipe Size Diameter	Bedding Thickness	Bedding Width 1.5 x Pipe	Water Main Bedding Mat. Area	Water Main Bedding Mat. #s/LF
4"	3"	6"	.125 Sq.Ft.	17.50
6"	3"	9"	.1875 Sq.Ft.	26.25
8"	3"	12"	.25 Sq.Ft.	35.00
10"	3"	15"	.3325 Sq.Ft.	46.55
12"	3"	18"	.375 Sq.Ft.	52.50
16"	3"	24"	.50 Sq.Ft.	70.00
20"	3"	30"	.625 Sq.Ft.	87.50
24"	3"	36"	.75 Sq.Ft.	105.00
30"	3"	45"	.9375 Sq.Ft.	131.25

* Length based on one (1) foot of main.

Issued: December, 2022

Watertown Municipal Utilities
901 4th Ave. SW
Watertown, S.D. 57201

**Water Main Bedding
And Trench Backfill**

Specification
Reference

Sheet
Number

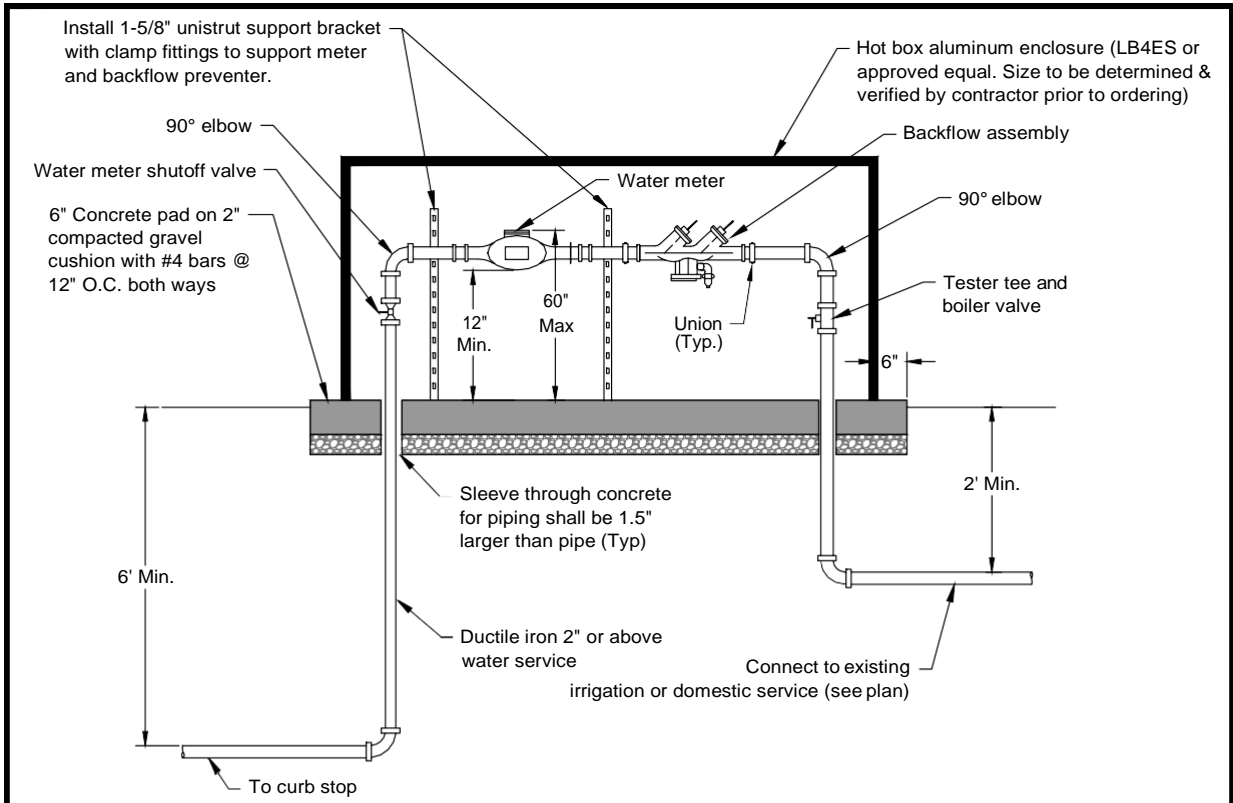

General Notes:

1. All enclosures are to be installed and connected onto a concrete base per manufacturer's recommendations and as detailed above.
2. All backflow assemblies shall be tested by a City approved, ABPA certified backflow technician prior to being put into service.
3. Backflow will be removed by owner during winterization procedures and stored. Install accordingly to allow annual removal.
4. Concrete pad to be constructed with class M6 concrete.
5. Submit shop drawings for approval of aluminum enclosure. Contractor is responsible for providing size recommendations to ensure 12" of interior clearance around all piping and equipment
6. All piping and fittings inside enclosure for irrigation service to 2 feet outside enclosure shall conform to city ordinance and engineering designs.
7. Keep meters and backflow assemblies centered (L&R) in enclosure.
8. For assemblies 3/4" - 2", Wilkins 375XL RP or the Wilkins 350XL DC shall be used.
9. All costs associated with construction of the water service from the shutoff valve, through the meter and backflow enclosure, to the PVC irrigation mainline connection shall be included in the unit price per each of "Meter and Backflow Enclosure"
10. The meter, backflow preventer and misc. pipe and fittings shall be enclosed as detailed above.
11. All costs associated with construction of the meter and backflow enclosure, including, the enclosure, concrete base, rebar and misc. Hardware shall be included in the unit price per each of "Meter and Backflow Enclosure."
12. All costs associated with meter and backflow enclosure piping from the curb stop to 24" outside the enclosure for the irrigation service shall be included in the unit per each bid item "Meter and Backflow Enclosure."
13. Water Department approval of meter and backflow
14. Building Services standard approval requirements apply.

Issued: December, 2022

<p>Watertown Municipal Utilities 901 4th Ave. SW Watertown, S.D. 57201</p>	<p>Typical Water Meter & Backflow Assembly with Enclosure</p>	<p>Specification Reference</p>	<p>Sheet Number</p>
--	--	------------------------------------	-------------------------

General Notes:

1. Curb stop boxes located within concrete or asphalt (driveway, sidewalk, parking and street) shall be fitted with a valve box top extension (8" minimum length) and 5.25" drop lid. The curb stop will be centered within the valve box top extension. The valve box top extension will sit flush with the finish grade.
2. The ball valve operational nut shall be located on the top half of the corporation stop upon installation.

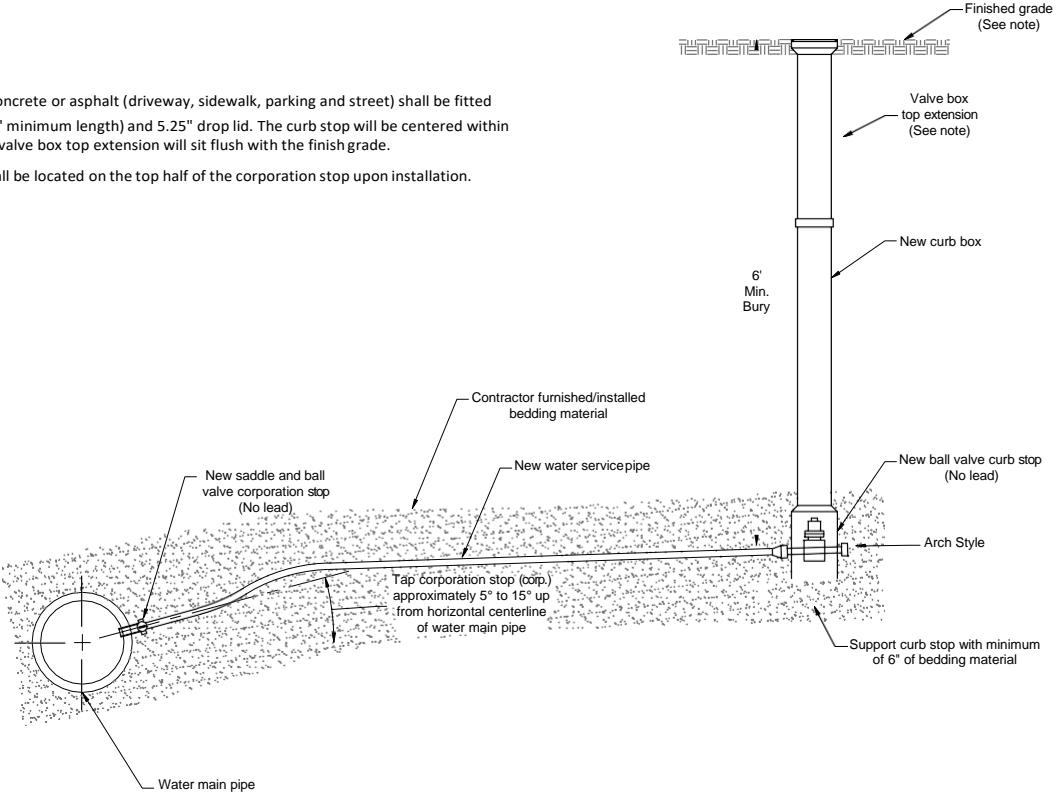

Issued: December, 2022

Water Service Installation		
Watertown Municipal Utilities 901 4th Ave. SW Watertown, S.D. 57201	Specification Reference	Sheet Number